

TM 11-5985-371-12&P

TECHNICAL MANUAL
OPERATOR'S AND
ORGANIZATIONAL
MAINTENANCE MANUAL
(INCLUDING REPAIR PARTS AND
SPECIAL TOOLS LIST)

ANTENNA AS-3577/GRC
(NSN 5985-01-148-1778)

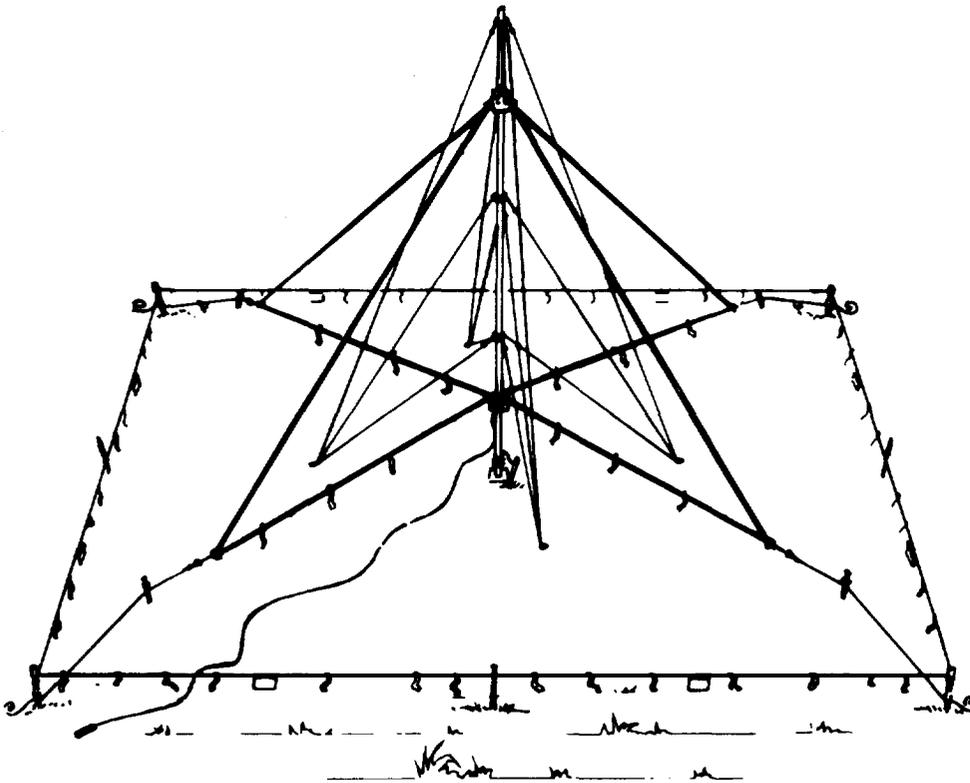

HEADQUARTERS DEPARTMENT
OF THE ARMY

1 SEPTEMBER 1986

TABLE OF CONTENTS	i
HOW TO USE THIS MANUAL	iii
EQUIPMENT DESCRIPTION AND DATA	1-3
OPERATOR PREVENTIVE MAINTENANCE CHECKS AND SERVICES	2-1
ASSEMBLY AND PREPARATION FOR USE	2-3
PREPARATION FOR MOVEMENT	2-23
ORGANIZATIONAL PREVENTIVE MAINTENANCE CHECKS AND SERVICES	4-5
ORGANIZATIONAL TROUBLESHOOTING	4-11
MAINTENANCE ALLOCATION CHART	B-4
REPAIR PARTS AND SPECIAL TOOLS LIST	F-1
GLOSSARY	Glossary 1
INDEX	Index 1



5

SAFETY STEPS TO FOLLOW IF SOMEONE IS THE VICTIM OF ELECTRICAL SHOCK

1

DO NOT TRY TO PULL OR GRAB THE INDIVIDUAL

2

IF POSSIBLE , TURN OFF THE ELECTRICAL POWER

3

IF YOU CANNOT TURN OFF THE ELECTRICAL POWER, PULL, PUSH, OR LIFT THE PERSON TO SAFETY USING A WOODEN POLE OR A ROPE OR SOME OTHER INSULATING MATERIAL

4

SEND FOR HELP AS SOON AS POSSIBLE

5

AFTER THE INJURED PERSON IS FREE OF CONTACT WITH THE SOURCE OF ELECTRICAL SHOCK, MOVE THE PERSON A SHORT DISTANCE AWAY AND IMMEDIATELY START ARTIFICIAL RESUSCITATION

WARNING

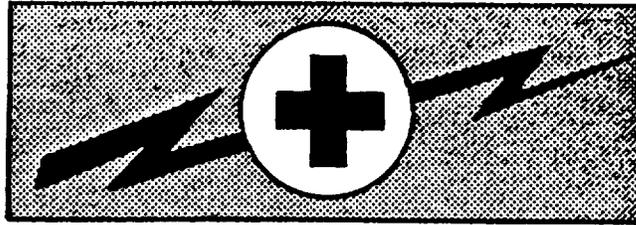

HIGH VOLTAGE

is used in the operation of this equipment

DEATH ON CONTACT

may result if personnel fail to observe safety precautions

Never work on electronic equipment unless there is another person nearby who is familiar with the operation and hazards of the equipment and who is competent in administering first aid. When the technician is aided by operators, warn them about dangerous areas.

Whenever possible, the power supply to the equipment must be shut off before beginning work on the equipment. Take particular care to ground every capacitor likely to hold a dangerous potential. When working inside the equipment, after the power has been turned off, always ground every part before touching it.

Be careful not to contact high-voltage connections or 115 volt ac input connections when installing or operating this equipment.

Whenever the nature of the operation permits, keep one hand away from the equipment to reduce the hazard of current flowing through the body.

Warning: Do not be misled by the term "low voltage." Potentials as low as 50 volts may cause death under adverse conditions.

For Artificial Respiration, refer to FM 21-11.

WARNINGS

Operator and maintenance personnel should be familiar with TB SIG 291 before attempting installation or operation of the antenna. Failure to follow the requirements of TB SIG 291 and the following warnings could result in injury or DEATH.

Never erect the antenna directly under power lines. If you must erect the antenna near power lines, power-line poles or towers, or buildings with overhead power-line connections, never erect the antenna closer than 100 feet from the base of power-line, pole, tower or building. If you suspect that power lines have made accidental contact with your antenna, do not touch any part of the antenna, stop operating, rope off the antenna area, and notify your superiors.

Do not try to erect, teardown or work on the antenna during an electrical storm or when a storm is imminent.

Never attempt to erect or teardown the antenna with less than two people. When erecting or tearing down the antenna, allow only team personnel in the erection/teardown area.

Before erecting the antenna, inspect all the parts. Do not erect the antenna if any parts are missing or damaged.

Rf radiation hazard to personnel exists when the antenna is connected to a transmitter and is especially hazardous when the rf power is 100 watts and personnel are within 8 inches of the antenna wire. If the antenna is connected to a transmitter, make sure the rf radiation hazard area is bounded by the safety area rope with the caution plates and warning strips attached. Before entering the area bounded by the safety area rope, make certain the transmitter is not transmitting and will not be "turned on".

In addition to the radiation hazard, when transmitting at 100 watts of radio frequency power, contact voltage potentials at selected points on the antenna wire are high enough to induce electrical shock.

Wear protective goggles while driving mast base, guy stakes, antenna stakes and safety rope stakes into the ground.

When selecting sites for erecting the antenna, try to avoid traveled areas and roads, and marshy or sandy terrain. If you cannot avoid traveled areas and roads, get specific instructions from your supervisor as to what clearance guys, ropes and antenna wire must have. If the ground in which the mast base, guy stakes and antenna stakes are to be inserted is marshy or sandy, get specific instructions from your supervisor on how to reinforce the mast base and stakes.

If the weather in your area can cause ice to form on your antenna and guys, get specific instructions from your supervisor regarding providing extra supporting guys.

Keep a sharp eye on your guys, guy stakes, antenna wire and antenna stakes. Check them daily and immediately before and after bad weather.

Adequate ventilation should be provided while using TRICHLOROTRIFLUOROETHANE. Prolonged breathing of vapor should be avoided. The solvent should not be used near heat or open flame; the products of decomposition are toxic and irritating. Since TRICHLOROTRIFLUOROETHANE dissolves natural oils, prolonged contact with skin should be avoided. When necessary, use gloves which the solvent cannot penetrate. If the solvent is taken internally, consult a physician immediately.

Lifting heavy equipment incorrectly can cause serious injury. Do not try to lift more than 35 lbs by yourself. Get a helper. Bend legs while lifting and don't support heavy weight with your back.



**OPERATOR'S AND ORGANIZATIONAL
MAINTENANCE MANUAL
(INCLUDING REPAIR PARTS AND
SPECIAL TOOLS LIST)
ANTENNA AS-3577/GRC
(NSN 5985-01-148-1778)**

REPORTING ERRORS AND RECOMMENDING IMPROVEMENTS

You can help improve this manual. If you find any mistakes or if you know of a way to improve the procedures, please let us know. Mail your letter, DA Form 2028 (Recommended Changes to Publications and Blank Forms), or DA Form 2028-2 located in the back of this manual direct to: Commander, US Army Communications-Electronics Command and Fort Monmouth, ATTN: AMSEL-ME-MP, Fort Monmouth, New Jersey 07703-5007. In either case, a reply will be furnished direct to you.

Page

HOW TO USE THIS MANUAL iii

CHAPTER	1	INTRODUCTION	
	Section I	<u>General Information</u>	1-1
	II	<u>Equipment Description and Data</u>	1-3
CHAPTER	2	OPERATING INSTRUCTIONS	
	Section I	<u>Operator Daily Preventive Maintenance Checks and Services (PMCS)</u>	2-1
	II	<u>Operation Under Usual Conditions</u>	2-3
	III	Operation Under Unusual Conditions	2-29
CHAPTER	3	OPERATOR MAINTENANCE INSTRUCTIONS	
	Section I	Lubrication Instructions	3-1
	II	Troubleshooting Procedure	3-1

CHAPTER 4 ORGANIZATIONAL MAINTENANCE

Section I Repair Parts, Special Tools, TMDE and Support Equipment 4-1

II Service Upon Receipt 4-1

III Organizational Preventive Maintenance Checks and Services (PMCS) 4-5

IV Principles of Operation 4-11

V Organizational Troubleshooting 4-11

VI Organizational Maintenance Procedures 4-16

VII Preparation for Storage or Shipment 4-24

APPENDIX A REFERENCES A-1

B MAINTENANCE ALLOCATION

Section I Introduction B-1

II Maintenance Allocation Chart B-4

III Tool and Test Equipment Requirements B-5

IV Remarks B-6

APPENDIX C COMPONENTS OF END ITEM LIST (COEIL)
(Not applicable)

D ADDITIONAL AUTHORIZATION LIST (AAL)
(Not applicable)

E EXPENDABLE SUPPLIES AND MATERIALS LIST

Section I Introduction E-1

II Expendable Supplies and Materials List E-2

APPENDIX F REPAIR PARTS AND SPECIAL TOOLS LISTS

Section I Introduction F-1

II Repair Parts List F-5

 Group 00 Antenna AS-3577/GRC (fig. F-1) F-5

 01 Antenna Mast Assembly AB-86/GRA-4 (No parts authorized (see TM 11-5985-229-12P)) (fig. F-1) F-5

 02 Terminating Resistor Box Assembly (fig. F-2) F-7

III Special Tools List (Not applicable)

IV National Stock Number and Part Number Index F-8

GLOSSARY

Section I Abbreviations Glossary1

II Terms Glossary1

INDEX INDEX 1

HOW TO USE THIS MANUAL

The front cover will assist you in quickly locating information. It identifies information frequently used. Each item appearing on the front cover is boxed and identified by topic with the page number in the manual where the information is located. The page in the manual used in conjunction with the front cover has a black box on the edge of the page. Bend the manual in half and follow the margin index to the page with the black edge marker.

Entries within the Table of Contents, which duplicate the entries on the front cover index, are highlighted with a box.

A complete, alphabetical, subject index is located in the back of the manual. This index should help you locate information under most likely looked for names.

CHAPTER 1

INTRODUCTION

Section I. GENERAL INFORMATION

1-1. Scope.

a. Type of Manual. This manual covers operator and organizational maintenance and includes Repair Parts and Special Tools List in appendix F.

b. Purpose of Equipment. Antenna AS-3577/GRC is a portable, omnidirectional, broadband antenna assembly that provides for transmission or reception of rf energy in the frequency range of 2 to 30 megaHertz (MHz).

1-2. Consolidated Index of Army Publications and Blank Forms. Refer to the latest issue of DA Pam 310-1 to determine whether there are new editions, changes, additional publications, or Modification Work Orders (MWOs) pertaining to the equipment.

1-3. Maintenance Forms, Records and Reports.

a. Reports of Maintenance and Unsatisfactory Equipment. Department of the Army forms and procedures used for equipment maintenance will be those prescribed by DA Pam 738-750 as contained in Maintenance Management Update.

b. Report of Packaging and Handling Deficiencies. Fill out and forward SF 364 (Report of Discrepancy (ROD)) as prescribed in AR 735-11-2/DLAR 4140.55/NAVMATINST 4355.73B/AFR 400.54/MCO 4430.3H.

c. Discrepancy in Shipment Report (DISREP) (SF 361). Fill out and forward Discrepancy in Shipment Report (DISREP) (SF 361) as prescribed in AR 55-38/NAVSUPINST 4610.33C/AFR 75-18/MCO P4610.19D/DLAR 4500.15.

1-4. Hand Receipt (-HR) Manuals. This manual has a companion document with a TM number followed by "-HR" (which stands for Hand Receipt). TM 11-5985-371-10-HR consists of preprinted hand receipts (DA Form 2062) that list end item related equipment (i.e., BII and AAL) you must account for. As an aid to property accountability, additional -HR manuals may be requisitioned from the Commander, Baltimore AG Publications Center, 2800 Eastern Blvd., Baltimore, MD 21220 in accordance with the procedures in chapter 3, AR 310-2, and DA Pam 310-10.

1-5. Reporting Equipment Improvement Recommendations (EIR). If your AS-3577/GRC needs improvement, let us know. Send us an EIR. You, the user, are the only one who can tell us what you don't like about your design. Put it on an SF368 (Quality Deficiency Report). Mail it to Commander, US Army Communications-Electronics Command and Fort Monmouth, ATTN: AMSEL-PA-MA-D, Fort Monmouth, New Jersey 07703-5000. We'll send you a reply.

1-6. Administrative Storage. Administrative storage of equipment issued to and used by Army activities will have preventive maintenance performed in accordance with the PMCS charts before storing. When removing the equipment from administrative storage, the PMCS should be performed to assure operational readiness. Disassembly and repacking of equipment for shipment or limited storage are covered in section VII of chapter 4.

1-7. Destruction of Army Electronics Materiel. Destruction of Army electronics materiel to prevent enemy use shall be in accordance with TM 750-244-2.

1-8. Nomenclature Cross-Reference List. Following is an alphabetical listing of the common names used in lieu of nomenclature in this manual. The nomenclature for which each common name is used is identified in the Nomenclature column.

COMMON NAME	NOMENCLATURE
Antenna	Antenna AS-3577/GRC
Blue guy	Guy MX-382A/GRA-4
Cable adapter	Adapter, Straight, Jack-to-Jack UG-29B
Carrying frame	Frame MX-1116/GRA-4
Guy plate	Guy Plate MX-378/U
Guy stake	Guy Stake GP-111/G
Halyard	Halyard MX-516/GRA-4
Insulator	Insulator MX-384/GRA-4
Mast assembly	Antenna Mast Assembly AB-86/GRA-4
Mast base	Mast Base AB-154/U
Mast section	Mast Section AB-85/GRA-4
Multimeter	Multimeter, Digital AN/PSM-45
Red guy	Guy MX-383A/GRA-4
Rf cable	Rf Cable Assembly CG-1889B/U (100 feet) (30.5 meters)
White guy	Guy MX-381A/GRA-4

Section II. EQUIPMENT DESCRIPTION AND DATA

1-9. Equipment Characteristics, Capabilities, and Features.

a. General. Antenna AS-3577/GRC is a portable, omnidirectional, broad band antenna.

b. Purpose. The antenna provides for transmission and/or reception of rf energy in the 2-30-MHz frequency range.

c. Used With. It is suitable for use with any high frequency (hf) single side band (SSB) radio on a normal path length of 0-380 miles (0-611 km).

d. Mobility. Components are packed in one carrying case weighing 260 lbs (108 kg). Four persons are required to lift or carry the carrying case. The antenna assembly can be unpacked and erected by two persons in 2 hours and disassembled and packed for movement in 2 1/2 hours.

e. Site Requirements. The antenna requires a minimum siting area of 120 feet by 70 feet (36.6 by 21.4 meters).

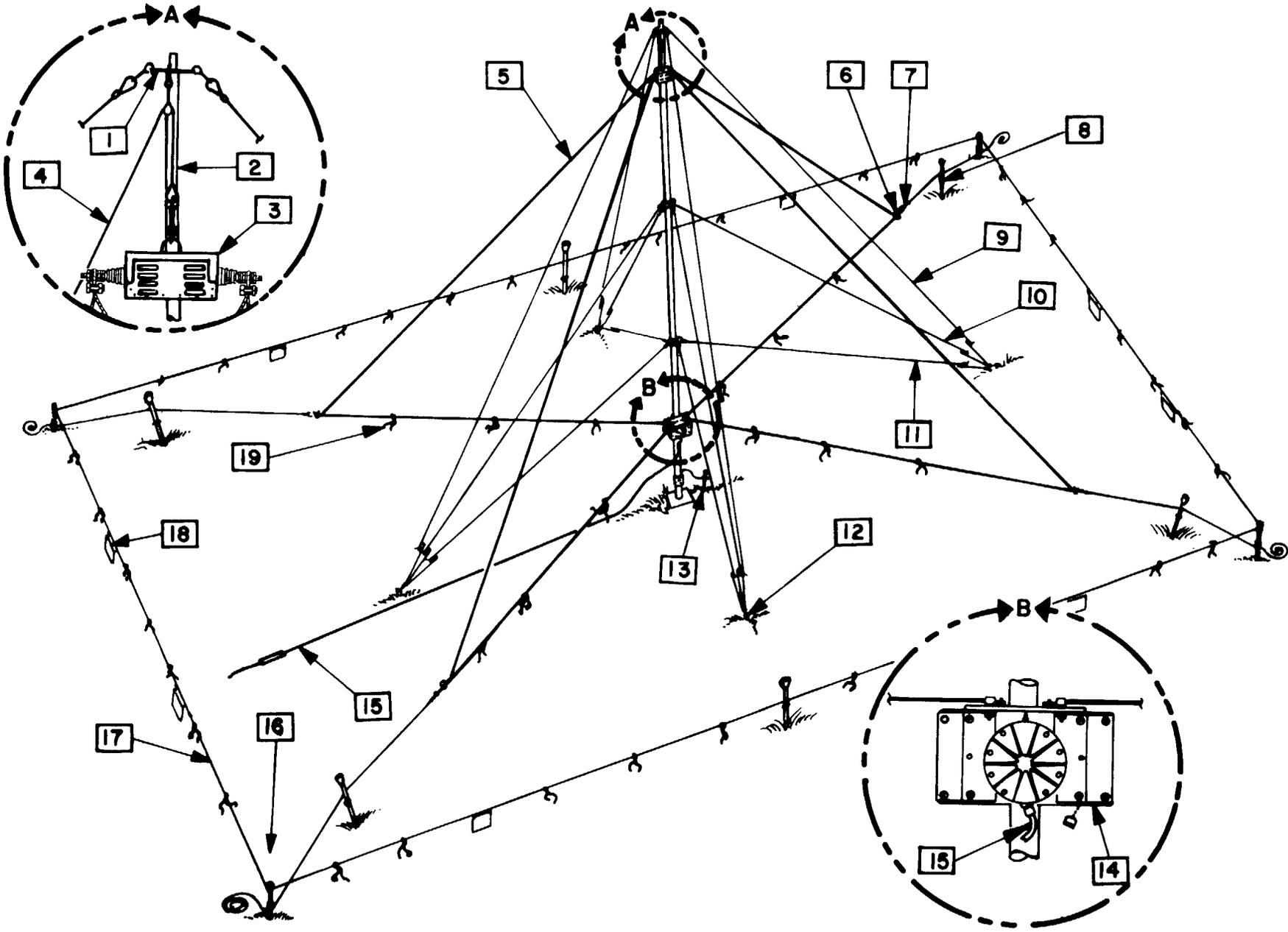

1-10. Location and Description of Major Components. Major components of the AS-3577/GRC are shown assembled for use and briefly described below.

- 1** GUY PLATE. Consists of a round steel plate 3 inches (7.6 cm) in diameter. The center hole fits over the male end of a mast section, and five of the eight outer holes serve for attaching the four guys and a halyard. Three guy plates are mounted on the mast.
- 2** MAST. The mast supporting the double delta antenna includes a mast base, a 6 inch square plate, insulator, and 16 identical 3-foot (0.92 meter) mast sections. When the mast sections are interconnected, the effective length of each section is 2.5 feet (0.76 meter). (See illustration on page 2-8.)
- 3** TERMINATING RESISTOR ASSEMBLY. The terminating resistor assembly includes a 600-ohm terminating resistor box, a terminating resistor box stop, and a terminating resistor box stop clamp which mounts the terminating resistor stop to the mast.
- 4** HALYARD. The halyard is a 140-foot (42.7 meter) nylon rope used to raise the terminating resistor box to the terminating resistor stop. In addition to the rope, the halyard includes a pulley attached to a snap hook, to attach to the top guy plate, and an eyelet to connect to the slide hook on the terminating resistor box.
- 5** ANTENNA WIRE. A 500-foot (152.5 meter) roll of AWG #14 antenna wire to construct the double delta antenna.
- 6** CONDUCTOR SPLICE. Three conductor splices are connected to each of the two antenna wires to form loops to attach to the antenna rod lanyards and the terminating resistor box.
- 7** LANYARD. Four 30-foot (9.15 meter) lanyards, consisting of color reflective orange nylon rope with a thimble and snap swivel at one end, connect the four antenna rods to the four legs of the double delta antenna. The lanyards also connect the antenna rod stakes to the safety area rope stakes to support the antenna rod stakes.
- 8** ANTENNA STAKES. Four antenna stakes assembled by connecting three identical ground rods, are provided. The antenna stakes are connected via insulating lanyards to the four legs of the double delta antenna. The antenna stakes and the safety area rope stakes (item **16**) are identical. Each ground rod is 3 feet long.
- 9** RED GUY. Four 50-foot (15.25 meter) guys to support the upper portion of the mast.
- 10** WHITE GUY. Four 40-foot (12.2 meter) guys to support the center portion of the mast.
- 11** BLUE GUY. Four 31-foot (9.46 meter) guys to support the lower portion of the mast.

NOTE

Depending on the manufacturer, the guys, items **9**, **10**, and **11** above, have a red, white, or blue color near the snap hook, or may have its length (50, 40, or 31 feet respectively) stamped near the snap hook.

12 GUY STAKE. Four 18-inch (45.7 cm) metal stakes anchor the guys in the ground. One spare guy stake is provided. A fastener, which is permanently attached to the top of the stake, connects to the adjustable fastener on the guy.

13 GROUND ROD AND GROUNDING CABLE. The ground rod is identical to the ground rods used for the antenna stakes **8** and the safety area rope stakes **16**, but it is furnished with a clamp and a grounding cable. (See illustration on page 2-19.)

14 BALUN ASSEMBLY. A 50-ohm to 600-ohm balun (impedance matching transformer) including a mounting assembly is attached to the mast 6.5 feet (2 meters) from the mast base.

15 RF CABLE ASSEMBLY. Two 100-foot (30.5 meter) rf cable assemblies are provided to connect the radio transmitter or receiver to the antenna. A cable adapter is furnished to connect two cables together.

16 SAFETY AREA ROPE STAKE. Six safety area rope stakes (identical to the antenna stakes, item **8**) support the safety area rope.

17 SAFETY AREA ROPE. A 300-foot (91.5 meter) roll of nylon rope and a 100-foot (30.5 meter) roll of nylon rope are provided to enclose the radiation hazardous area of the antenna. The two rolls must be tied together to form a 400-foot (122 meter) rope.

18 CAUTION PLATE. Eight rf radiation hazard plates are attached to the safety area rope when the antenna is used for transmitting.

19 WARNING STRIPS. The warning strips are furnished in two, rolls, one of which is 3/4 inch (1.91 cm) wide, and the other is 2 inches (5.08 cm) wide, and are made of international orange, fluorescent nylon webbing.

1-11. Components of Antenna AS-3577/GRC.

a. Components of Antenna AS-3577/GRC. Components of the AS-3577/GRC are identified and illustrated in paragraph 1-10. Items 1, 2, 9, 10, 11, and 12 are components of the AB-86/GRA-4 which are also components of the AS-3577/GRC. In addition; the AS-3577/GRC includes a sledge hammer, a 100-foot tape measure, a tool kit for installation and maintenance, and a carrying case. Refer to appendix F for details.

b. Components of Antenna Mast Assembly AB-86/GRA-4. Components of the AB-86/GRA-4 are described and illustrated in TM 11-2651. The following components which are part of the AB-86/GRA-4 are not furnished when the AB-86/GRA-4 is part of Antenna AS-3577/GRC:

- (1) Antenna Adapter MX-857/GRA-4
- (2) Counterpoise CP-12
- (3) Wire W-128

1-12. Equipment Data.

a. Technical Characteristics

Frequency range 2-30 MHZ
Radiation pattern Omni directional

Antenna type	Double delta
Normal range	0-380 miles (0-611 km)
Power rating	1 kw (maximum)
Input impedance	50 ohms
Terminating impedance	600 ohms
Insertion VSWR	Less than 2.3 to 1
Insertion loss	Less than .5 db
Adjustments	None
Alignment	None

b. Weights and Dimensions of Antenna Assembly.

(1) Ready for Movement (Packed). All the components of the AS-3577/GRC are packed in one carrying case (see illustration on page 4-27), which is equipped with four carrying handles. The carrying case is 4.125 feet long, 1.875 feet wide, and 1.5 feet deep (1.258 by 0.572 by 0.457 meters, respectively). It weighs 260 lbs (.108 kg) .

(2) Ready for Use (Erected).

Height	40 feet (12.2 meters)
Site dimensions	120 x 70 feet (36.6 x 21.4 meters)

1-13. Configuration Differences. There is a difference in the configuration of operable transmitting and receiving antenna assemblies. Only transmitting antenna assemblies require the caution (rf radiation hazard) plates attached to the safety area rope.

CHAPTER 2
OPERATING INSTRUCTIONS

WARNING

Rf radiation and electrical shock hazards to personnel exist when the antenna is connected to a radio transmitter. Prior to entering the area bounded by the safety area rope, make certain the transmitter is not transmitting and will not be "turned on".

Section 1. OPERATOR DAILY PREVENTIVE MAINTENANCE CHECKS AND SERVICES (PMCS)

2-1. General. The antenna has neither operator controls nor indicators, therefore, the term "operator" refers to the operator of the transmitter or receiver connected to the antenna. Operator daily PMCS is performed only on an erected antenna. Always keep in mind the CAUTIONS and WARNINGS immediately following the front cover of the manual while performing your PMCS.

2-2. Operator PMCS Procedures. Table 2-1 lists the PMCS which must be performed by the operator.

a. Purpose. PMCS is done to ensure that the equipment is ready for use at all times. These checks and services help you find and fix defects before the equipment is damaged or fails.

b. Item No. Column. Item numbers in the first column indicate the order in which things are to be done. Use the Item No. column to get the numbers for the TM Item No. column on DA Form 2404, Equipment Inspection and Maintenance Worksheet.

NOTE

Record all defects found during the performance of PMCS and the steps taken to fix them on DA Form 2404.

c. Item to be Inspected/Procedure Column.

(1) Item to be Inspected. The item to be inspected is described and illustrated.

(2) Procedure. The procedure by which the check is performed and the results are described.

d. Equipment Not Ready/Available if Column. The criteria that will cause the equipment to be classified as not ready/available for readiness reporting purposes.

Table 2-1. Operator Daily Preventive Maintenance Checks and Services

Item No.	Item to be Inspected Procedure	Equipment Not Ready/Available If:
<p>WARNING</p> <p>See WARNING on previous page.</p>		
1	Mast. Make sure the mast 1 is straight and vertical .	Mast not vertical .
2	<u>Guys and Antenna Wire.</u> Make sure the 12 guys 2 and the antenna wire 3 are secure and reasonably taut.	Guys and antenna wires loose or not secure.
3	Guy Stakes, Mast Base, and Antenna Stakes. Make sure the four guy stakes 4 , mast base and ground rod 5 and four antenna stakes 6 are firmly imbedded in the ground.	Stakes or mast base not firmly imbedded.
4	<u>Rf Cable and Grounding Cable.</u> Make sure the rf cable/cables 7 and grounding cable 5 and connectors are not loose, cut, kinked, broken, crushed, frayed or improperly positioned.	Cables frayed, broken or improperly positioned.
5	<u>Safety Area Rope.</u> Make sure the safety area rope 8 , tapes 9 , warning strips 10 and caution plates 11 (for transmitting) are properly erected.	Safety area not roped off, or warning strips not attached.

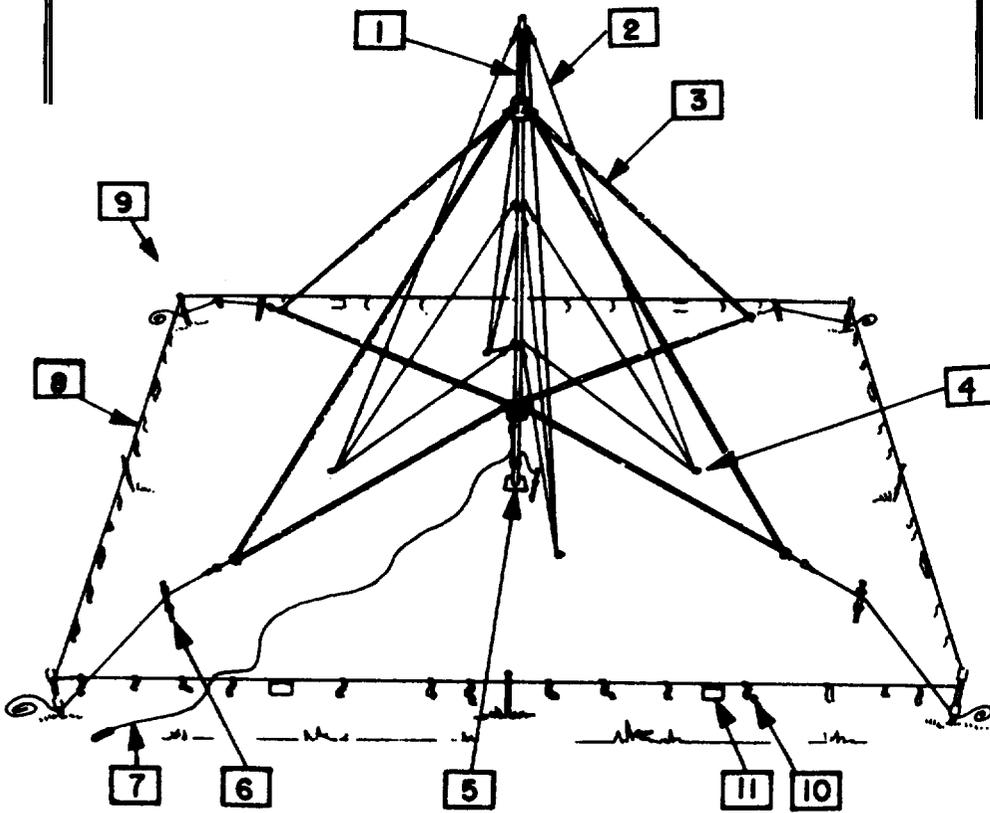

Section II. OPERATION UNDER USUAL CONDITIONS

2-3. General. Antenna AS-3577/GRC has neither operating controls nor indicators. This section covers siting (para 2-4), assembly and preparation for use (para 2-5), and preparation for movement (para 2-6).

WARNINGS

- NEVER ERECT THE ANTENNA DIRECTLY UNDER POWER LINES.
- If you must erect the antenna near power lines, power-line poles, power-line towers, or buildings with overhead power-line connections, never put the antenna closer than 100 feet from the base of a power-line, power pole, tower or building.
- Make sure the area for inserting the mast base and guy stakes, antenna rods, and safety rope stakes is firm. If the ground is marshy or sandy, see paragraph 2-7 for specific instructions on how to reinforce the mast base and stakes. See paragraphs 2-8 through 2-11 for other possible hazardous conditions.
- When selecting antenna sites, avoid traveled areas and roads. If you cannot avoid these areas, get specific instructions from your supervisor as to what clearance your guy wires and ropes must have over traveled areas and roads.

2-4. Siting. The ideal location for erecting the antenna is the center of a plateau having no natural or artificial obstructions or electrical interference sources such as radar equipment or power transmission lines nearby. When possible, select a level 120 by 70-foot (36.6 by 21.4 meter) plot of dry ground having good drainage to provide a firm base for the mast base, guy stakes, antenna stakes and safety-rope stakes. When communicating with two or more distant stations, locate the antenna in a site most favorable to the station most difficult to receive.

2-5. Assembly and Preparation for Use.

WARNINGS

- Personnel should be familiar with the requirements of TB SIG 291; failure to follow the requirements of TB SIG 291, could result in injury or death.
- If you suspect that power lines have made accidental contact with the antenna, do not touch the antenna assembly, immediately stop operation, rope off the antenna area, and notify your supervisor.

a. General.

(1) Warnings. Read the WARNINGS immediately following the cover page of the manual prior to installing the antenna assembly and keep them in mind during installation.

(2) Personnel. At least two people must be available to install the antenna assembly.

(3) Tools. All of the tools needed to install the antenna assembly are provided with the assembly. A hammer, 100-foot tape measure, and 1/4 inch slotted screwdriver are required.

b. Unpacking Carrying Case. See section II in chapter 4.

c. Placement of Mast Base.

(1) Using the 100-foot tape measure, locate and mark the center of the 120-foot by 70-foot plot chosen for the antenna site.

WARNING

Wear protective goggles while driving the mast base into the ground.

(2) Place the square plate **2** on the ground at the center. Set the swivel **1** on the mast base such that its male connector **3** is at a right angle to its ground stake **4** held vertically. Place the ground stake **4** through the hole in the plate **2** and point the swivel toward the center of the short side of the antenna site (point A). Put on protective goggles. Hammer the ground stake **4** vertically into the ground at the center of the antenna site. Remove the protective goggles.

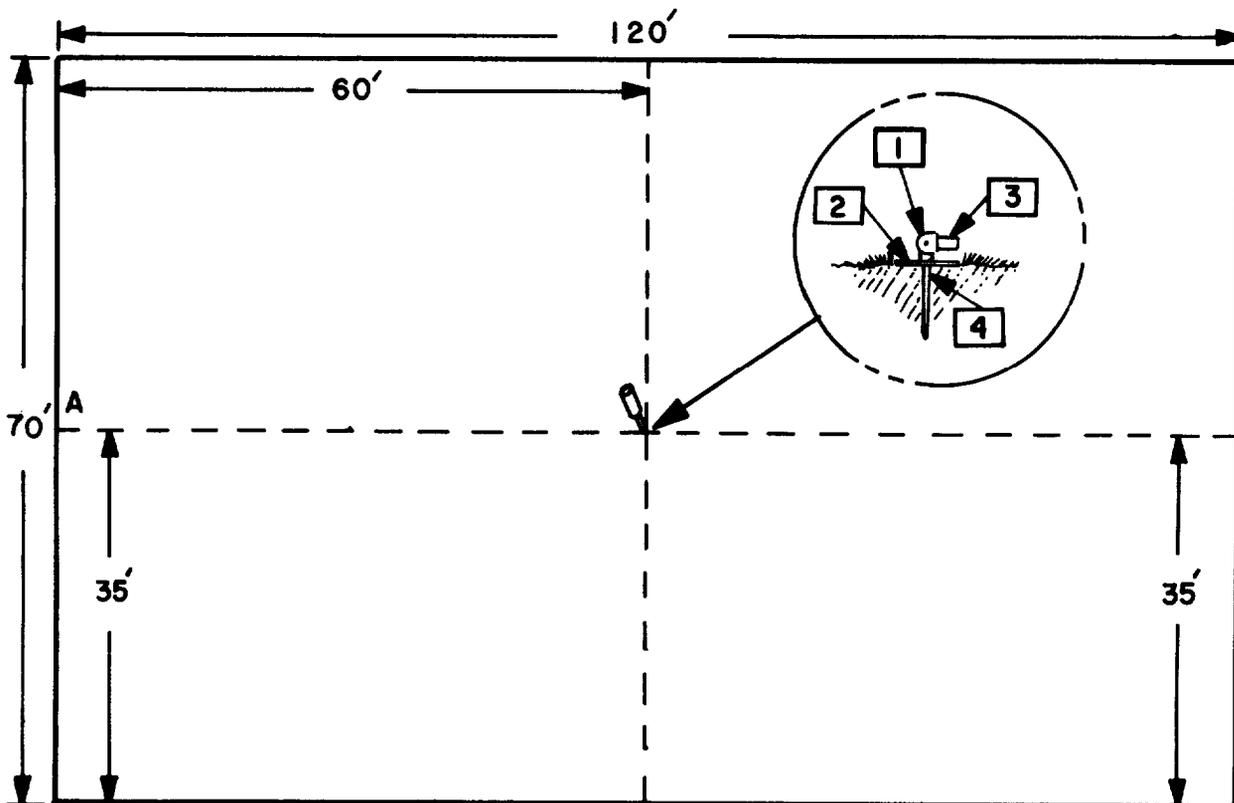

d. Placement of Guy Stakes.

WARNING

Wear protective goggles while driving the four guy stakes into the ground. If the soil is either sandy or soft, see paragraph 2-7.

(1) General . The letters A, B, C, and D assigned to the guy stakes in the illustration (2) below are for purposes of illustration only. The assigned letters are not markings on the equipment. Use the 100-foot tape measure to make the measurements cited below. After locating each guy stake as described below, put on the protective goggles, and use the hammer to drive each guy stake into the ground at an approximate angle of 30° from vertical and away from the mast base ground stake. Drive each guy stake into the ground until only the guy connector is above ground.

(2) Locating Guy Stakes . Locate guy stake A 25 feet (8.75 meters) from the mast base in the direction of the male connector **2** on the mast base swivel **1** as shown below. Drive guy stake A into the ground. Locate guy stakes B, C, and D approximately 90° apart as illustrated below and drive each guy stake into the ground.

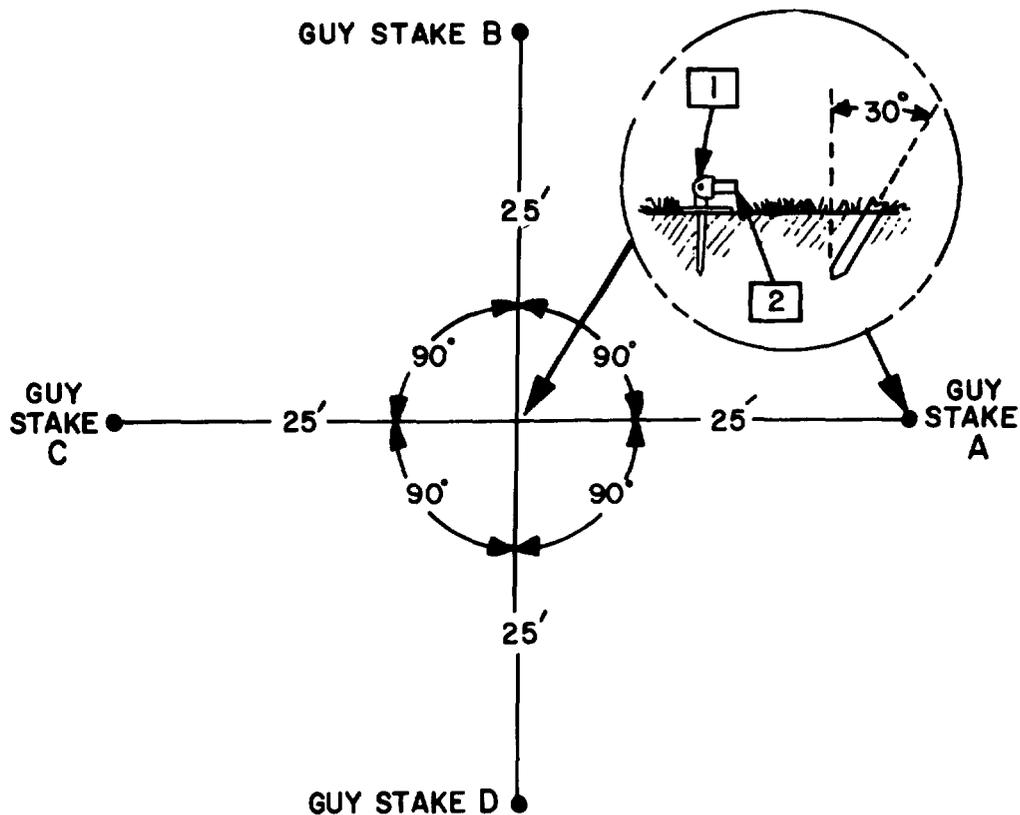

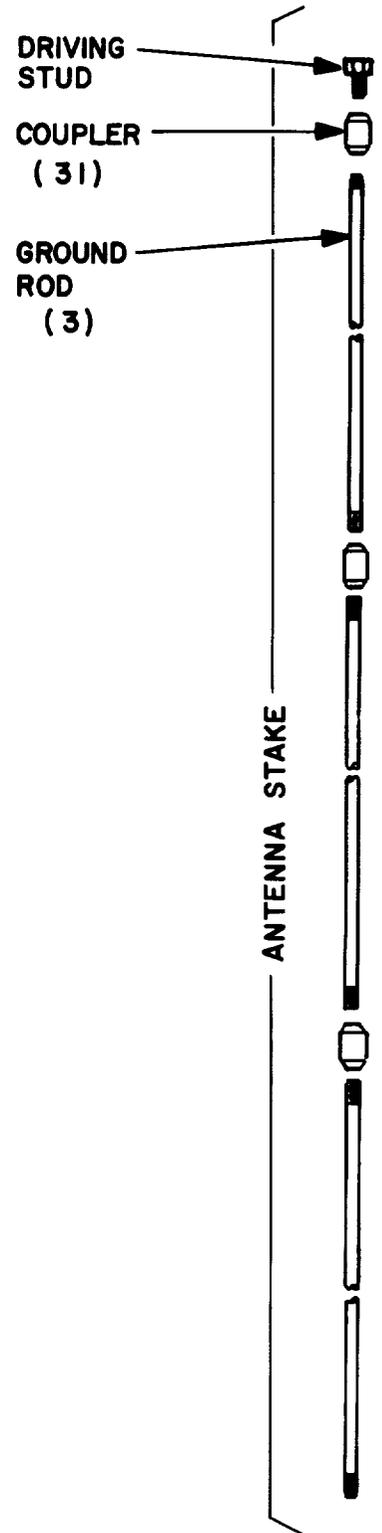
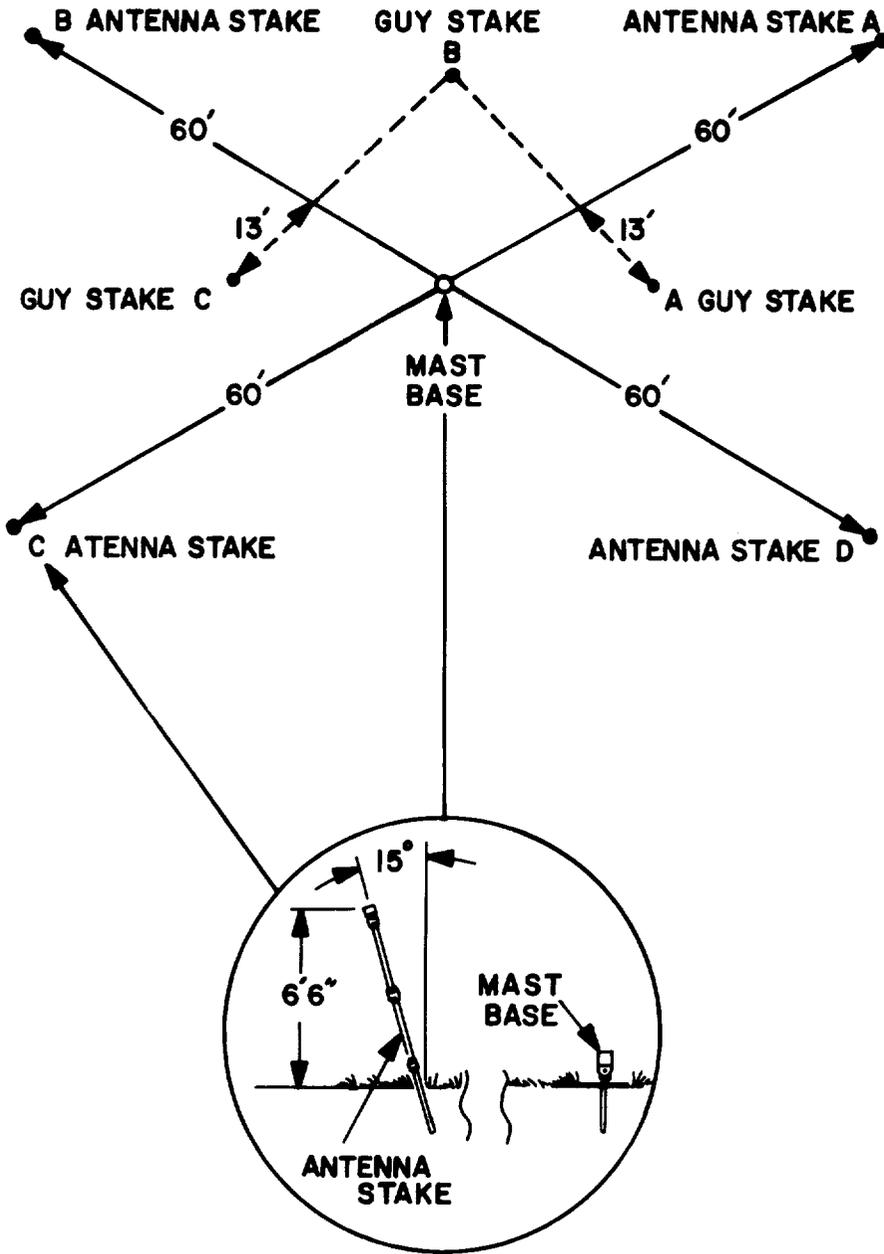

e. Placement of Antenna Stakes.

(1) General. The antenna stakes are assembled by using three ground rods without the grounding cable and clamps. (See illustration on page 2-19 and opposite page.) To lay out the positions of the four antenna stakes, letters A, B, C, and D are assigned for illustration purposes only. The letters are not markings on equipment. Use the 100-foot tape measure to make measurements cited below.

(2) Antenna Stake A.

(a) Connect the tape measure between guy stakes A and B. Measure and make a mark on the ground 13 feet (3.965 meters) from guy stake A. Connect the tape measure from the mast base through the 13-foot mark and measure 60 feet (18.3 meters) from the mast base. Mark the spot.

CAUTION

Before hammering in the ground rod, make sure that the driving stud, which connects to the ground rod via the coupler, bottoms firmly on the ground rod.

(b) Attach the coupler to the ground rod; attach the driving stud to the coupler, making sure the driving stud bottoms firmly on the ground rod.

(c) Put on protective goggles and hammer the ground rod into the ground approximately 15° away from the vertical and the mast base, until about 5 inches of the ground rod and coupler are above ground.

(d) Remove the driving stud. Connect a second ground rod to the first with the coupler; and a third ground rod to the second with a coupler. Place a coupler and the driving stud on top of the third ground rod.

(3) Antenna Stake B.

(a) Connect the tape measure between guy stakes B and C. Measure and make a mark on the ground 13 feet from guy stake C. Connect the tape measure from the mast base through the 13-foot mark and measure 60 feet from the mast base. Mark the spot.

(b) Repeat steps (2)(b), (c), and (d) above.

(4) Antenna Stake C.

(a) Measure 60 feet from the mast base in a direction opposite the direction of antenna stake A. Mark the spot.

(b) Repeat steps (2)(b), (c), and (d) above.

(5) Antenna Stake D.

(a) Measure 60 feet from the mast base in a direction opposite the direction of antenna stake B. Mark the spot.

(b) Repeat steps (2)(b), (c), and (d) above.

f. Assembly of Mast. With the female end of the insulator and each mast section facing the mast base, place the insulator and the 16 mast sections on the ground, in a line from the mast base to guy stake A. Insert the female end of the insulator over the male end of the mast base. Insert the female end of the mast section nearest the insulator over the male end of the insulator. Add the next four mast sections (mast sections 2 through 5) allowing the mast sections to rest on the ground. Place a guy plate on the male end of mast section 5. Add mast sections 6 through 10 and place a guy plate on the male end of mast section 10. Add mast sections 11 through 16 and place a guy plate on the male end of mast section 16.

g. Attaching Terminating Resistor Stop to Mast. Using the terminating resistor stop clamp **1** and four wingnuts **2**, mount the terminating resistor stop **3** 2 foot 8 1/2 inches (0.52 meter) from the top of the mast **4**.

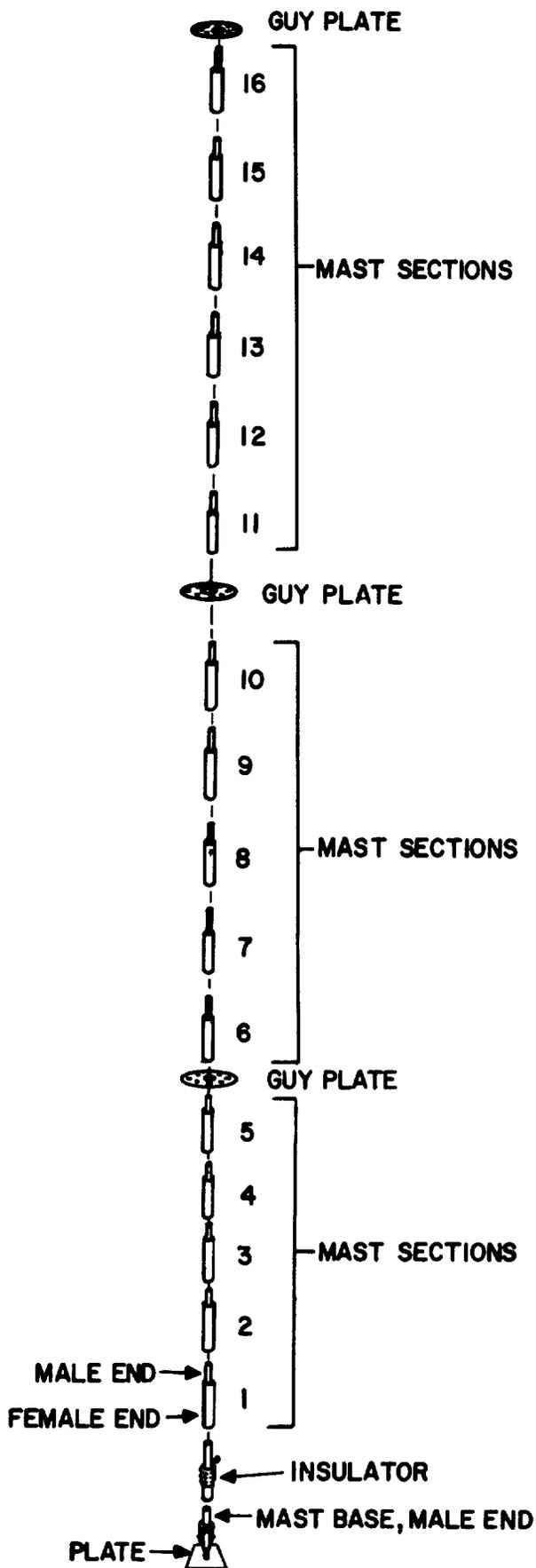
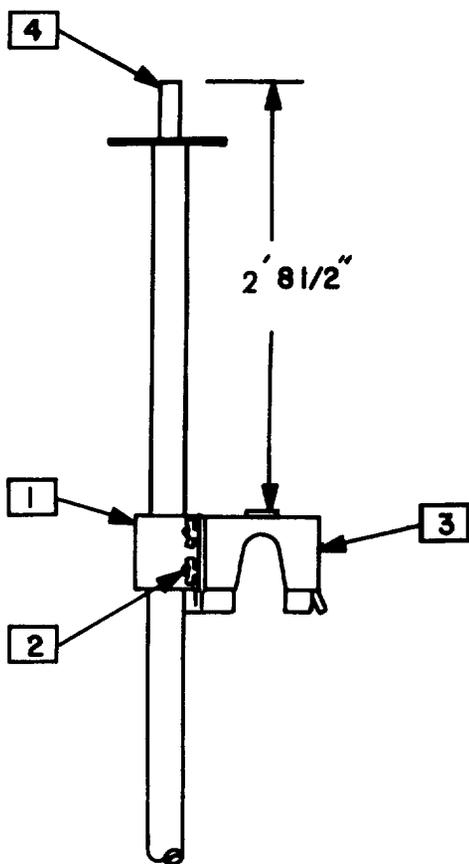

WARNING

Before connecting the halyard to the mast, inspect the rope for worn spots, frays, rotted portions and any other faults. Replace a defective rope before connecting the halyard.

h. Attaching Halyard to Mast. Connect the pulley snaphook **1** to a hole in the top guy plate **2**. Rotate the top guy plate so the hole connected to the halyard **3** is on the same side of the mast as the terminating resistor stop **4**. Thread the eyelet **5** on the halyard through the hole in the terminating resistor stop **4**. Thread the other end of the halyard through the pulley **6** and tie the two ends of the halyard together.

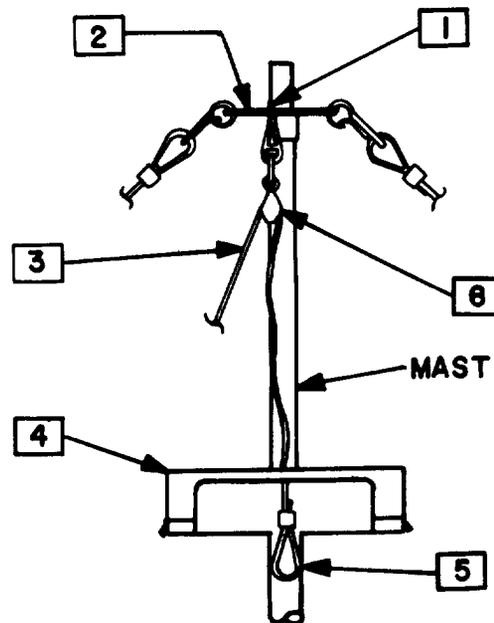

i. Attaching Guys to Mast and Guy Stakes.

WARNING

Before attaching the guys, inspect guy ropes for worn spots, frays, rotted portions and other faults. Replace defective rope/ropes before erecting the mast.

(1) General. The guys are color coded (or marked in feet) for identification.

Top guy - red - 50 feet (15.25 meters).
 Center guy - white - 40 feet (12.2 meters).
 Bottom guy - blue - 31 feet (9.46 meters).

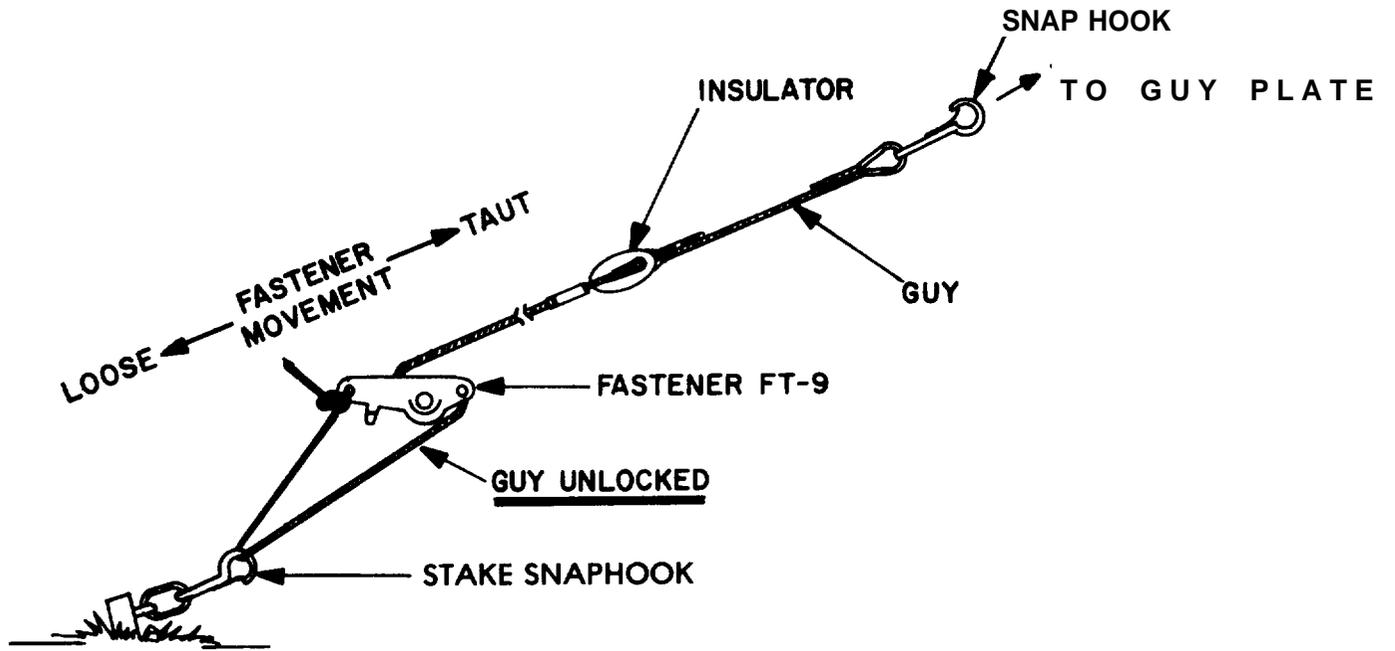

ADJUSTING POSITION

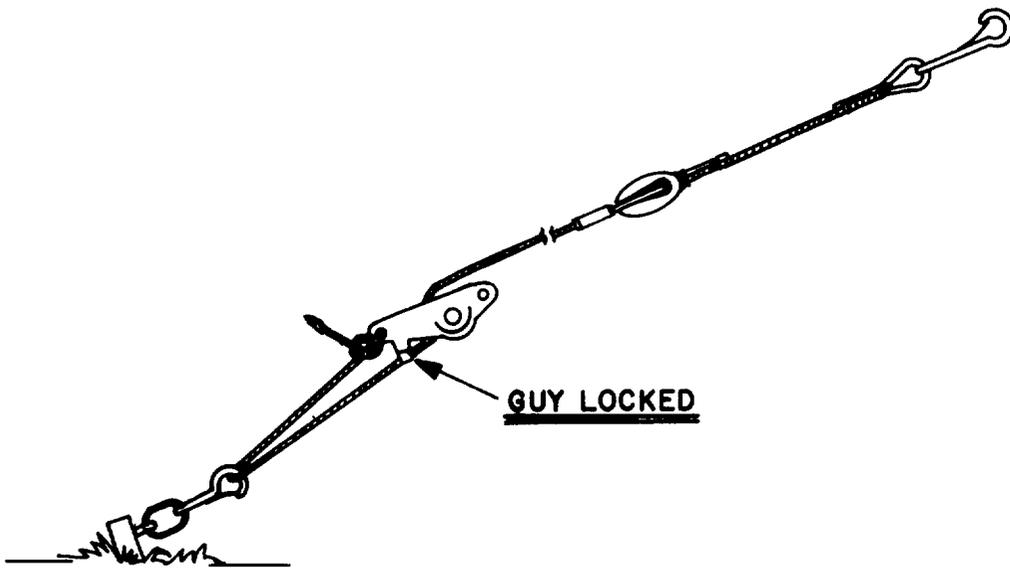

ADJUSTED POSITION

(2) Stake A Guys. Attach the snaphook on a red guy to the guy hole nearest the ground in the top guy plate. Attach the snaphook on a white guy to the guy hole nearest the ground in the center guy plate. Attach the snaphook on a blue guy to the guy hole nearest the ground in the bottom guy plate. Being careful not to tangle the guys, carry the free end of each of the three guys to guy stake B and attach the three guys to guy stake B. Adjust Fastener FT-9 on each guy to tighten the guys. While adjusting Fasteners FT-9, be careful not to bend the mast. Disconnect the three guys from guy stake B, coil each guy, lay the coils on the ground next to guy stake A and attach the loose end on each guy to guy stake A.

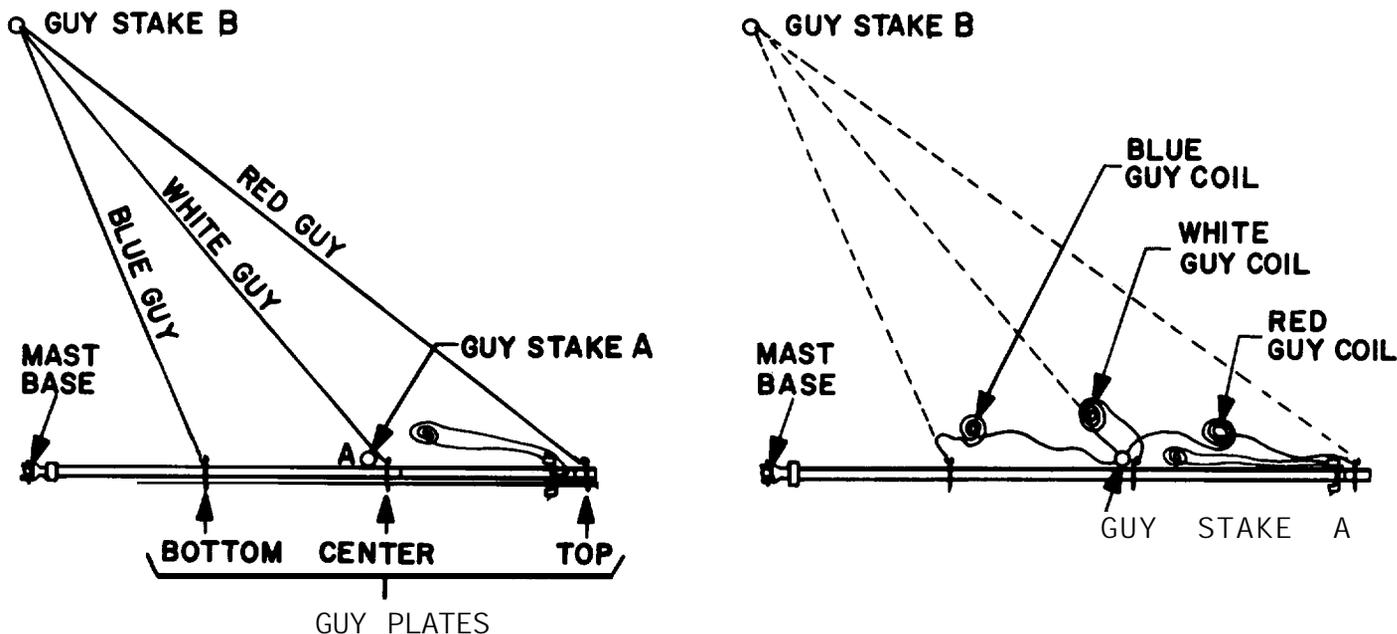

(3) Stake B Guys. The snaphooks on the guys to be connected to guy stake B are connected to the guy holes in the guy plates counterclockwise from the guy holes occupied by the snaphooks of the stake A guys.

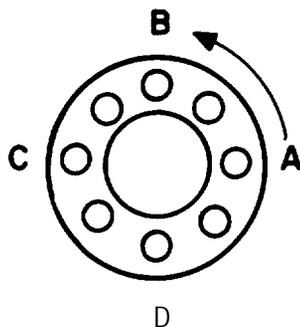

VIEW FROM TOP OF
MAST

Attach the snaphook on a red guy **1** to the B guy hole in the top guy plate **2**. Attach the snaphook on a white guy **3** to the B guy hole in the center guy plate **4**. Attach the snaphook on a blue guy **5** to the B guy hole in the bottom guy plate **6**. Being careful not to tangle the guys, carry the free end of each of the three guys to guy stake B **7** and attach the three guys to guy stake B **7**. Adjust Fastener FT-9 on each guy to tighten the guys. While adjusting Fasteners FT-9, be careful not to bend the mast.

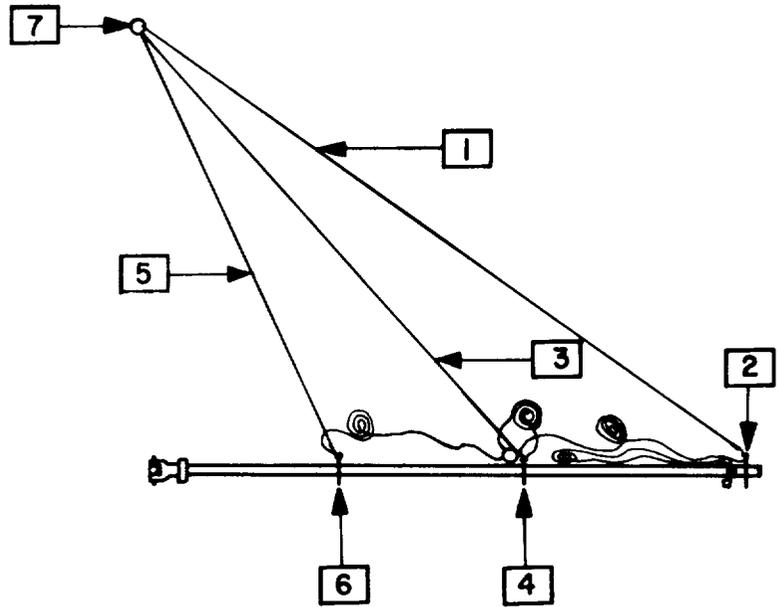

(4) Stake D Guys. The snaphooks on the guys to be connected to guy stake D are connected to the guy holes in the guy plates clockwise from the guy holes occupied by the snaphooks on the stake A guys.

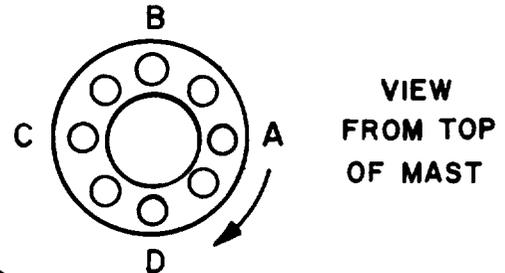

Attach the snaphook on a red guy **1** to the D guy hole in the top guy plate **2**. Attach the snaphook on a white guy **3** to the D guy hole in the center guy plate **4**. Attach the snaphook on a guy **5** to the D guy hole in the bottom guy plate **6**. Being careful not to tangle the guys, carry the free end of each guy to guy stake D **7** and attach the three guys to guy stake D. Being careful not to bend the mast, adjust Fastener FT-9 on each guy to tighten the guy.

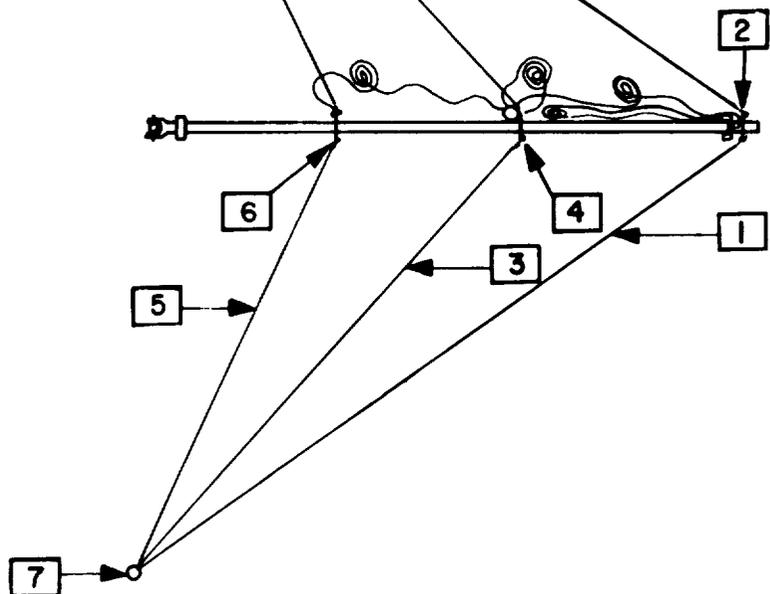

(5) Stake C Guys. The snaphooks on the guys to be connected to guy stake C **1** are connected to the guy holes in the guy Plates opposite the guy holes occupied by the snaphooks on the stake A guys **2**. Attach the snaphook on the remaining red guy **3** to the C guy hole in the top guy plate **4**. Attach the snaphook on the remaining white guy **5** to the C guy hole in the center guy plate **6**. Attach the remaining blue guy **7** to the C guy hole in the bottom guy plate **8**. Stretch the guys along the mast toward guy stake C **1**. The guys are not connected to guy stake C **1** until after the mast is raised (j below).

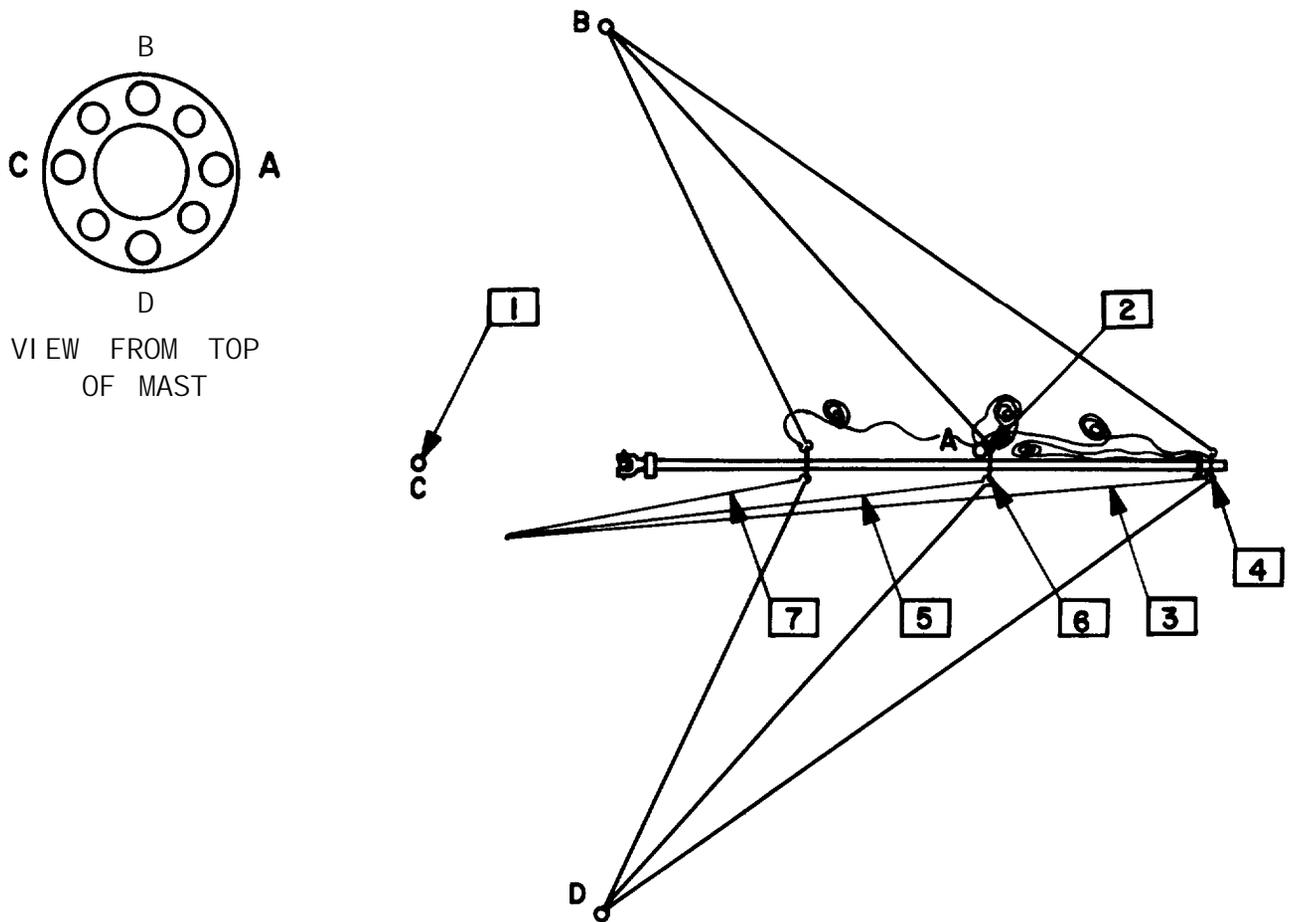

WARNINGS

- Do not try to raise the mast during an electrical storm or when a storm is imminent.
- Do not try to raise the mast without at least two people.
- When raising the mast, allow only the personnel involved in raising the mast in the area.
- If the antenna must be erected when the ground is wet, frozen or slippery or the wind is blowing at a rate greater than 15 miles per hour (13 knots), at least four people (two at each location) should be available.

CAUTION

Before raising the mast, make sure the mast base swivel is positioned so that it will hinge (bend) toward guy stake C.

j. Raising the Mast.

(1) Two people are required to raise the mast. One person stands near the mast base **1**, the second stands near the top of the mast **2**.

(2) Person 1 pulls on the free set of guys **3** (guys to be connected to guy stake C **4**) being sure to keep more tension on the top (red) guy **5** so that the mast bows slightly. At the same time, Person 2 lifts the top of the mast **2** from the ground and raises it above his-head.

(3) Person 1 walks slowly backward toward guy stake C **4** while pulling on the guys **3**. At the same time, person 2 walks slowly forward toward the mast base **1** raising the mast as he goes.

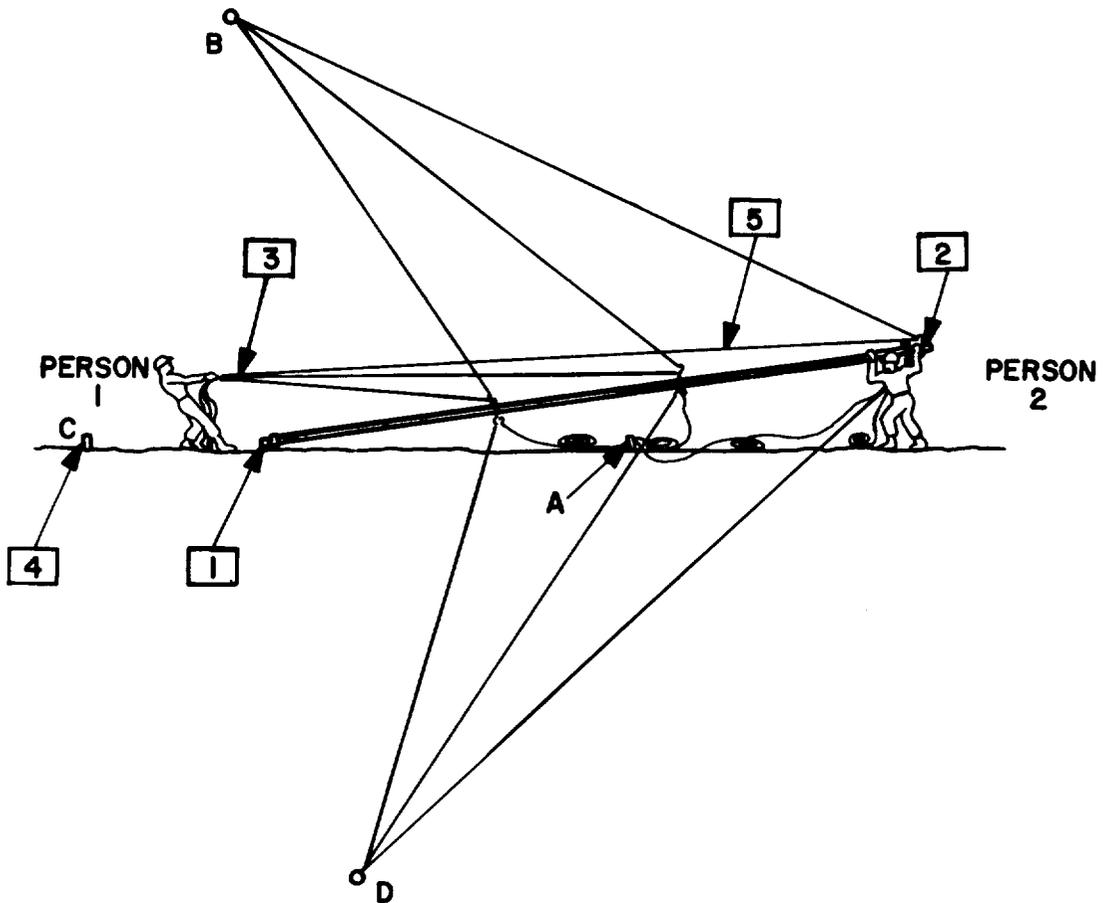

(4) When the mast **1** is upright and the guys held by person 1 are taut, being careful not to tangle the guys, person 2 attaches the red guy **2**, then the white guy **3** and last the blue guy **4** to guy stake C **5**.

(5) If further adjustment is necessary to bring the mast more nearly vertical, first slack off the guys that are too short, then tighten the guys that are too long, and finally tighten the guys that were slacked off.

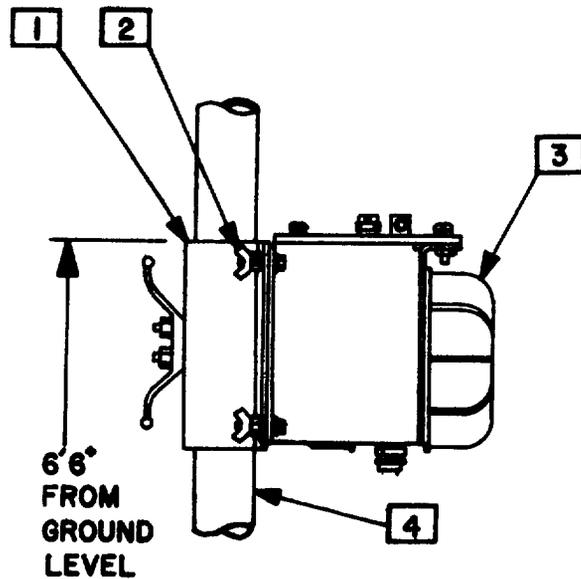

k. Assembly of Double Delta Antenna.

(1) Mounting the Balun. Using the balun clamp assembly **1** and four wingnuts **2**, mount the balun **3** to the mast **4** 6 feet 6 inches (2 meters) above ground level the balun clamp on the same side of the mast **4** as the terminating resistor stop clamp (para g above).

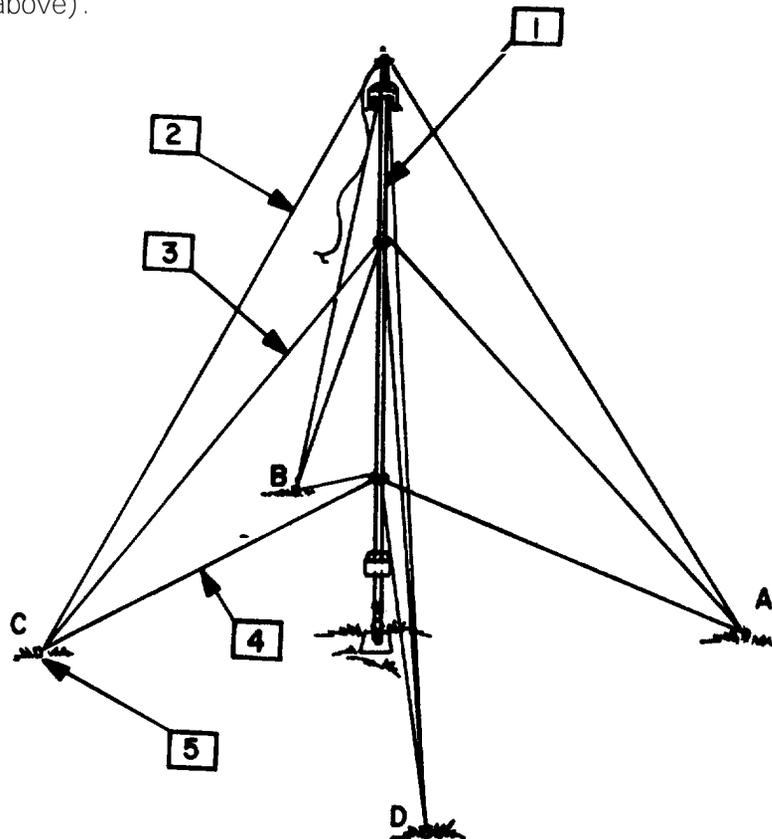

(2) Preparing Antenna Wire and Connecting to Terminating Resistor Box.

(a) Cut two 220-foot (67.1 meter) pieces of antenna wire from the 500-foot (152.5 meter) roll.

(b) Thread one antenna wire at midpoint (110 feet from each end between two flat washers on antenna connector **1** on the terminating resistor box **2** and secure by tightening hex nut. (Antenna connector **1** will hold the antenna wire going to antenna stakes B and C). Place and tighten a conductor splice **3** at the midpoint.

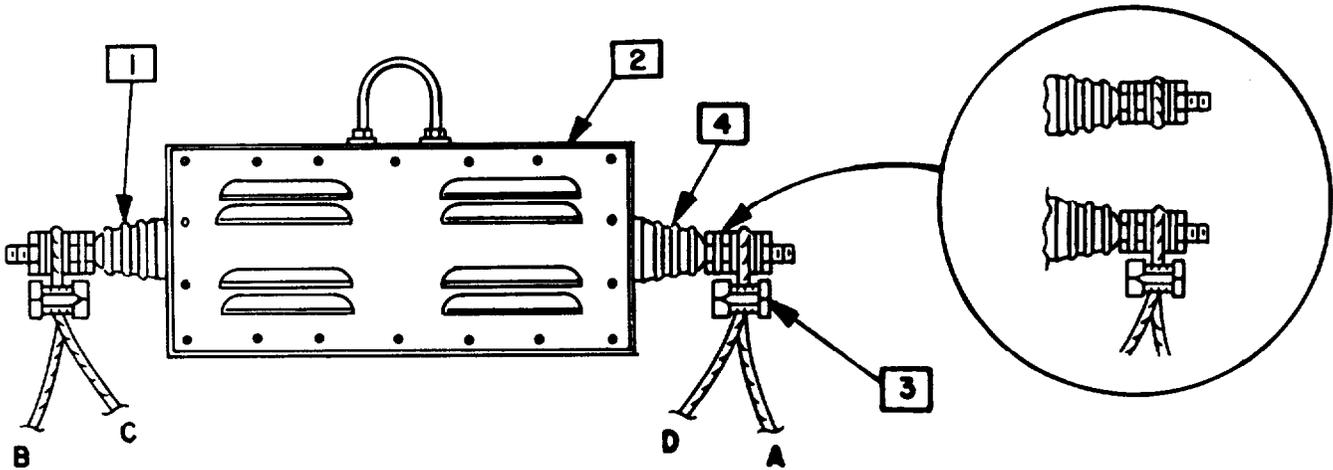

(c) Measure 60 feet (18.3 meters) from the midpoint on each loose end of each antenna wire, make a loop and place a conductor splice at each point. These loops will connect to the antenna stake lanyards.

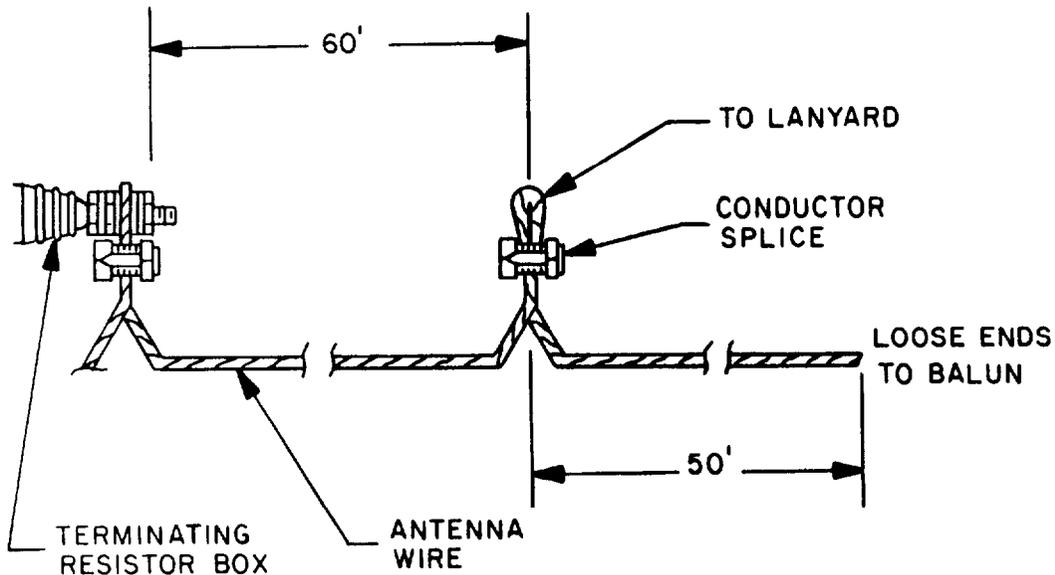

(d) Repeat the procedure ((b) and (c) above) for the antenna wire to be connected to terminating resistor box antenna connector **4** (Antenna connector **4** will hold the antenna wire going to antenna stakes A. and D).

(3) Raising Terminating Resistor Box. Untie the two ends of the halyard **1**. Attach the slide hook **2** on the terminating resistor box **3** to the eyelet **4** on the halyard **1**. Pull the loose end **5** of the halyard to raise the terminating resistor box **3** until it reaches the terminating resistor stop **6**. Make sure the antenna wires are located between the middle and to guys. Tie the loose end **5** of the halyard to the cleat **7** on the balun clamp **8**.

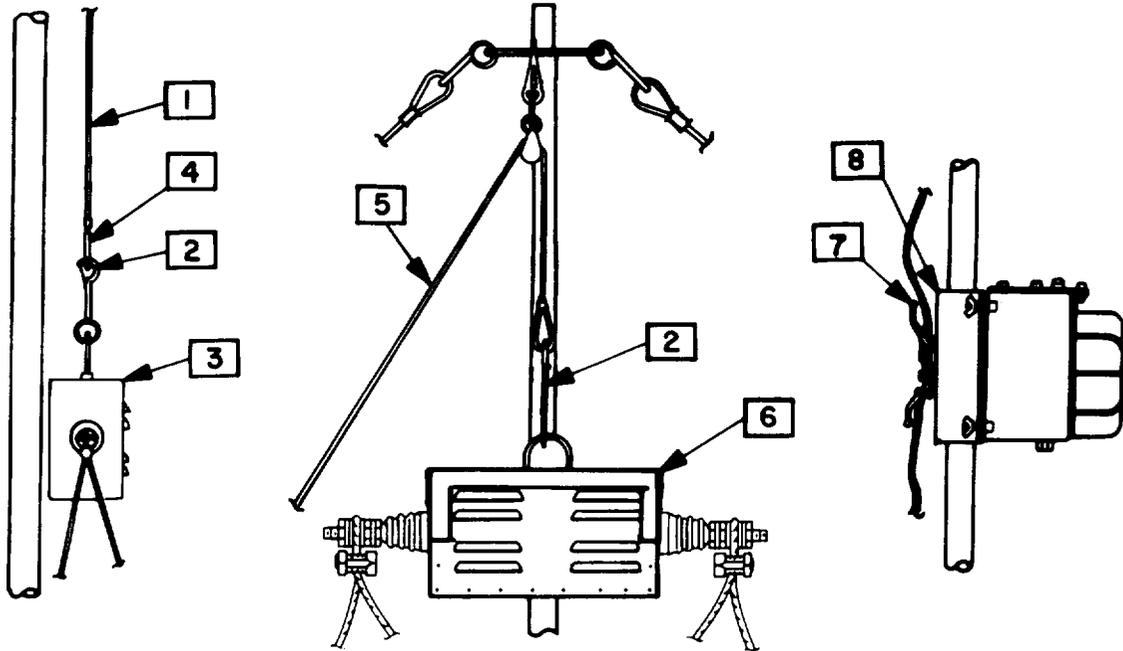

(4) Connecting Antenna Wire to Lanyards. Tie one lanyard to each antenna stake, leaving 0 feet from the antenna stake to the snaphook. Connect one end loop **1** on one antenna wire to the snaphook **2** of the lanyard **3** connected to antenna stake B **4**. Attach the other end loop of the same antenna wire to the lanyard connected to antenna stake C. Attach one end loop on the other antenna wire to the snaphook on the lanyard connected to antenna stake A and the other end loop to the lanyard connected to antenna stake D. Place warning strips **5** on the antenna.

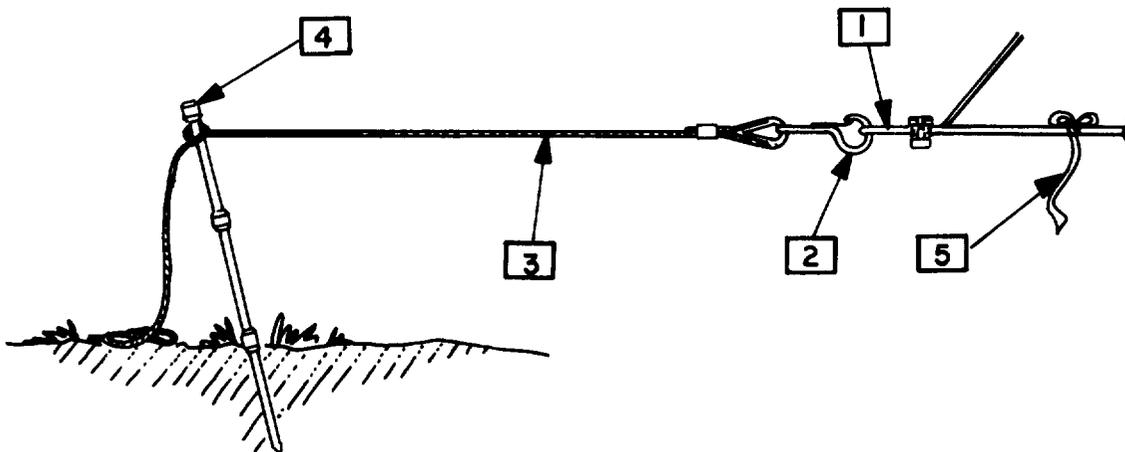

(5) Connecting Antenna Wire to Balun. Connect the two loose ends **1** of the piece of antenna wire (going to antenna stakes B and C) to antenna connector A **2** on top of the balun **3**. Connect the two loose ends **4** of the other piece of antenna wire (going to antenna stakes A and D) to antenna connector B **5**.

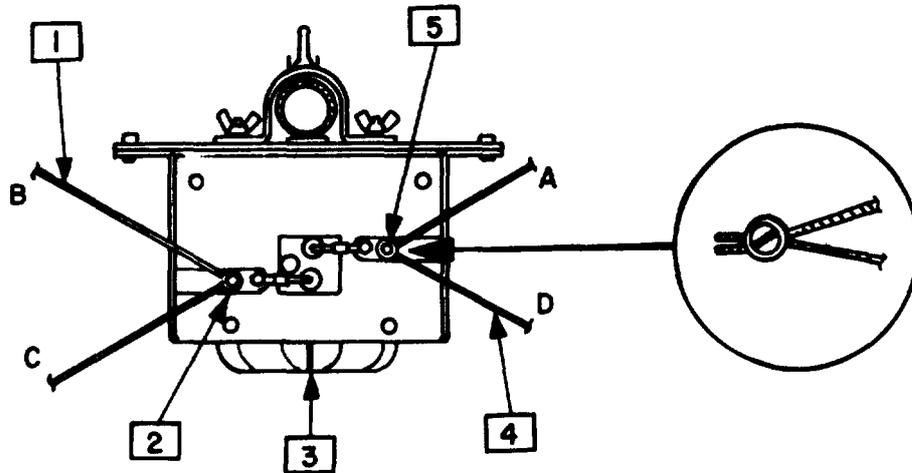

WARNING

If the antenna is to be connected to a transmitter, make certain that the transmitter is not transmitting and will not be turned on prior to connecting the rf cable/cables between the antenna and the transmitter.

CAUTION

Route the rf cable from the antenna assembly to the receiver/transmitter so that it will not be damaged by vehicles.

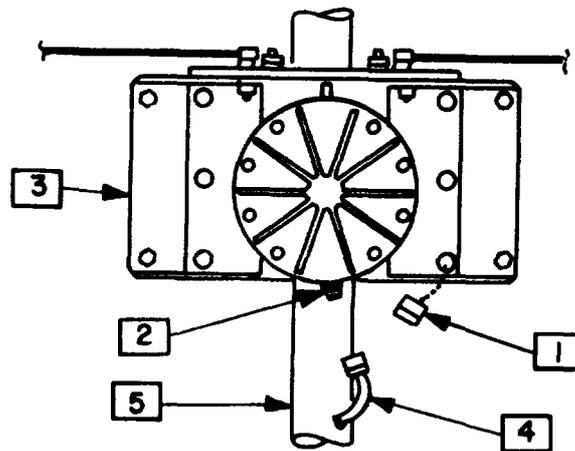

1. Connecting Rf Cables.

Remove the protector cap **1** from the connector **2** on the bottom of the balun **3**. Tie one end of one of the 100-foot (30.5 meter) rf cables **4** to the mast base **5** leaving enough of the end of the cable **4** to connect the cable to the balun. If the other end of the 100-foot rf cable does not reach the connector on the transmitter/receiver, use the cable adapter **6** to connect a second 100-foot rf cable.





Before hammering in the ground rod, make sure that the driving stud, which connects to the ground rod via the coupler, bottoms firmly on the ground rod.

m. Connecting Insulator to Ground Rod.

(1) Select the round rod **1**, clamp **2**, and grounding cable **3**. screw the coupler **4** firmly into the ground rod **1**, and screw the driving stud **5** into the coupler, making sure the driving stud bottoms on the ground rod.

(2) Put on protective goggles and hammer the ground rod until approximately 6 inches remain above ground. Remove the protective goggles.

(3) Strip 2" of insulation from both ends of grounding cable.

(4) Fold one end of ground cable in half **3** and place between clamp **2** and ground rod **1** and tighten out.

(5) Connect other end of grounding cable **3** firmly to the insulator connection **6** and tighten screw.

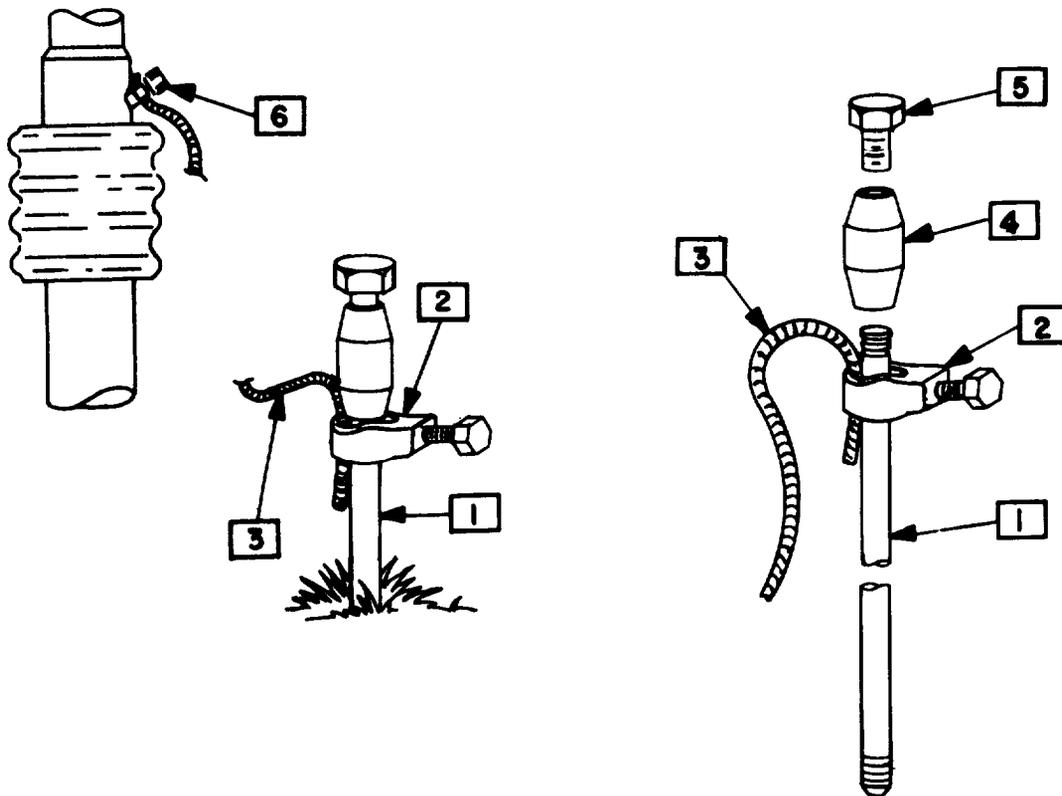

n. Erection of Safety Area Boundary.

WARNING

- RF radiation and electrical shock hazards to personnel exist when the antenna is connected to a transmitter.
- If the antenna is connected to a transmitter, make certain the rf radiation hazard area is bounded by the safety area rope with the caution plates and warning strips attached. In an emergency, use strips of white cloth as warning strips.
- Make certain the transmitter is not transmitting and will not be "turned on" prior to entering the area to be enclosed by the safety area rope.

(1) Safety Area Rope Stakes. Connect the 100-foot tape measure from the mast base, and pass it adjacent to the base of antenna stake A. Measure and mark a point 9½ feet (2.89 meters) beyond antenna stake A. This point is to be the location of the first safety rope stake. Repeat the procedure going from the mast base to each antenna stake and marking a point on the ground 9½ feet beyond each antenna stake. Connect the 100-foot tape measure from the mast base and run the tape adjacent to guy stake B and mark a point on the ground 35 feet (10.68 meters) from the mast base. Repeat the procedure going from the mast base, adjacent to guy stake D and marking a point 35 feet from the mast base. These ground points will be used for the six safety rope stakes.

WARNING

Wear protective goggles while driving the six safety rope stakes into the ground.

CAUTION

Before hammering in the ground rod, make sure that the driving stud, which connects to the ground rod via the coupler, bottoms firmly on the ground rod.

(a) The safety area rope stakes are assembled by using three ground rods without the grounding cable and clamp. (See illustration on page 2-6.) Screw the coupler to the ground rod, and screw the driving stud to the coupler, making sure the driving stud bottoms firmly on the ground rod.

(b) Put on protective goggles and hammer the ground rod vertically into the ground until about 5 inches are above ground.

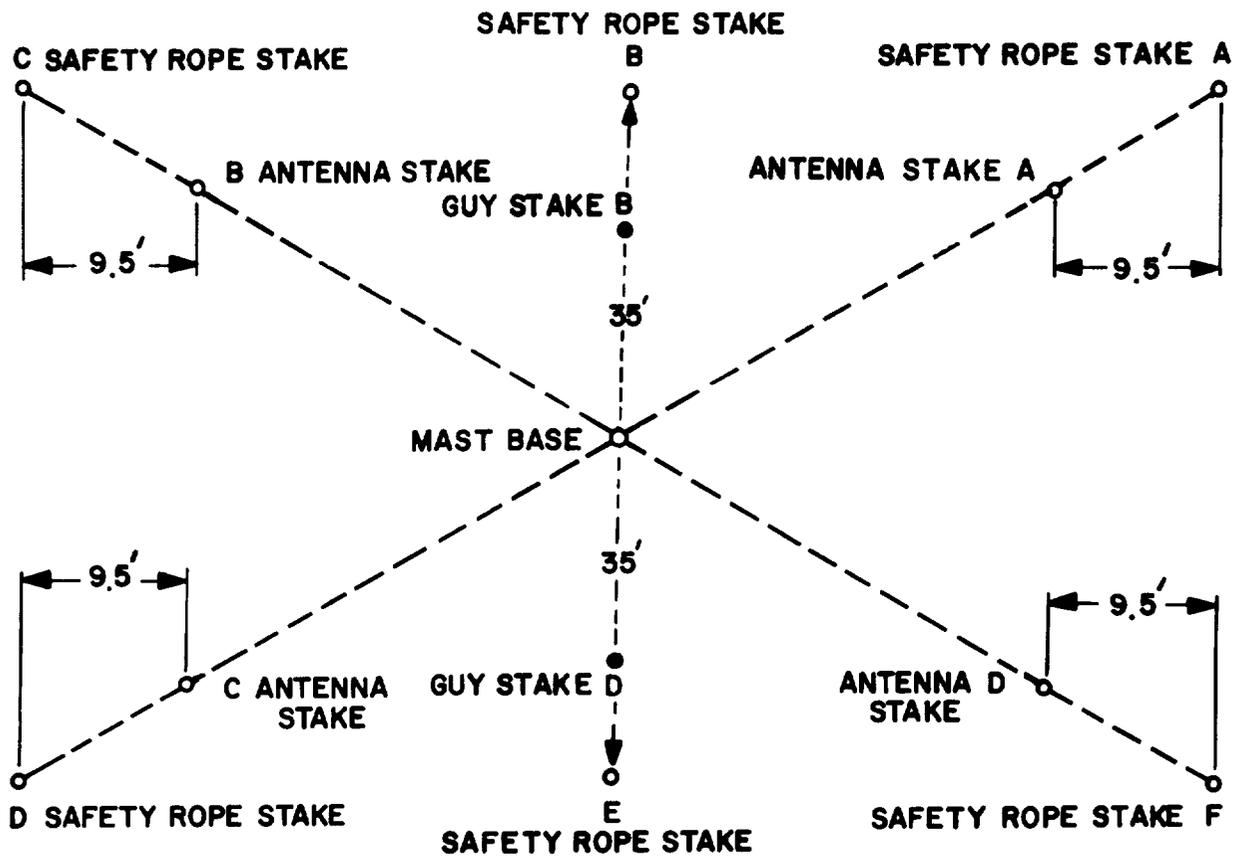

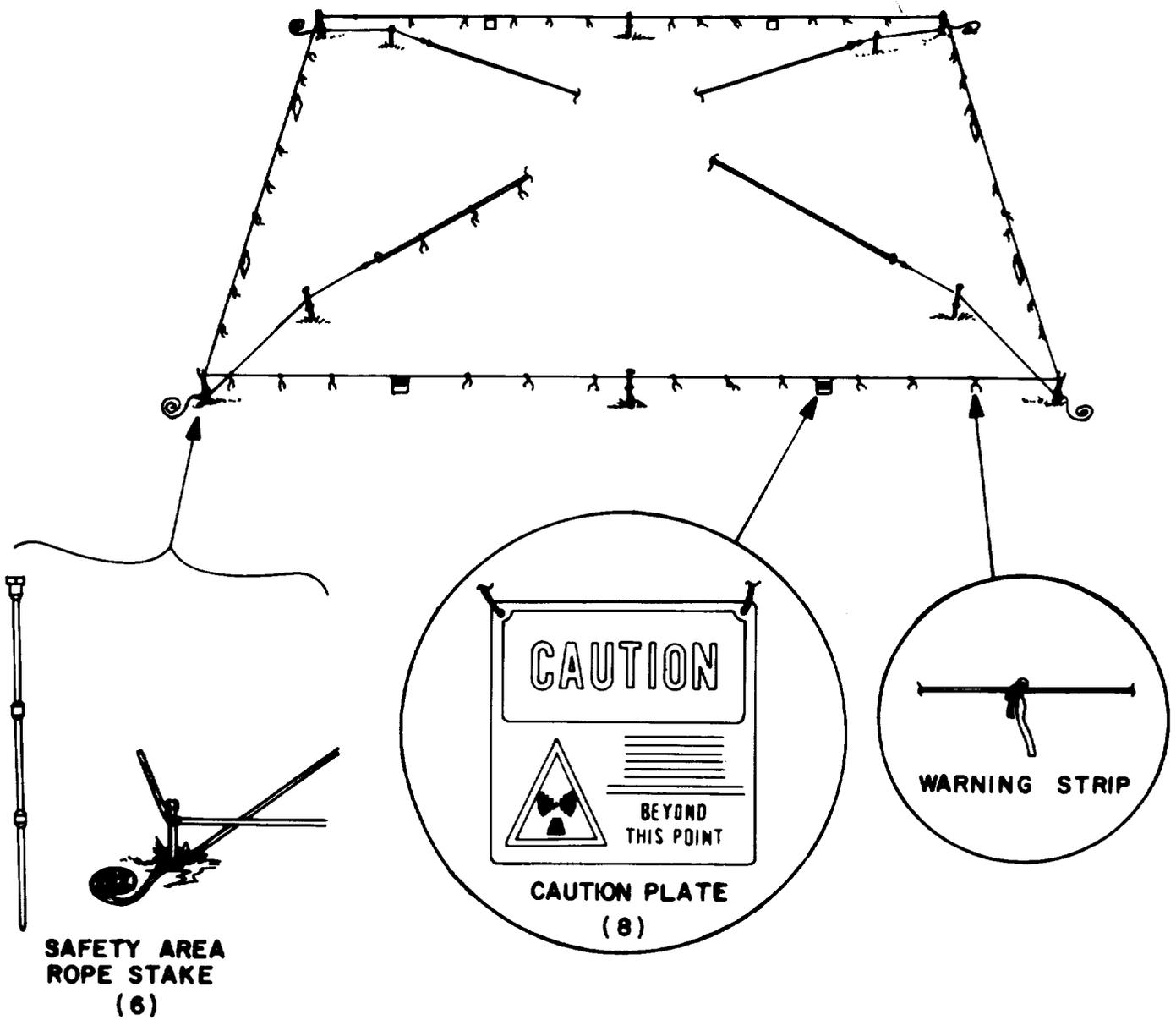

(c) Remove the driving stud, connect a second ground rod to the first with a coupler, and screw in the driving stud. Put on protective goggles and hammer in the ground rod until about 5 inches are above ground.

(d) Remove the driving stud. Connect a third ground rod to the second ground rod with the coupler, and screw the driving stud to the coupler on the third ground rod.

(e) Repeat the procedure ((a) through (d) above) at the five other marked locations.

(2) Safety Area Rope. Tie one end of the 300-foot roll of orange safety rope to one end of the 100-foot roll of identical rope. Tie one end of the resultant 400-foot safety area rope to the top of one safety area rope stake. Extend the rope around the perimeter of the safety area and tie the rope at the top of the five remaining safety area rope stakes. Coil the remaining rope and lay it on the ground near the last stake.

(3) Caution Plates and Warning Strips. Attach two caution plates on each side of the area safety rope, each approximately 30 feet from the corner stakes on the 120-foot sides; and 17 feet from the corner stakes on the 70-foot sides. Attach the 24 orange warning strips as shown. Alternate between the 3/4-inch and the 2-inch wide warning strips.

(4) Antenna Stake Lanyards. To support the antenna stakes, tie each lanyard to the top of the adjacent safety rope stake at each corner. Coil and lay the remaining part of the lanyard on the ground near the safety rope stake.

2-6. Preparation for Movement.

WARNING

- If the antenna is connected to a transmitter, make certain the radio operator has disconnected the antenna rf cable from the transmitter before entering the roped off rf radiation hazard area.
- Do not try to take down the antenna during an electrical storm.

a. Disconnecting Ground Rod from Insulator.

- (1) Disconnect the grounding cable **1** from the insulator connector **2**.
- (2) Pull the ground rod **3** from the ground.

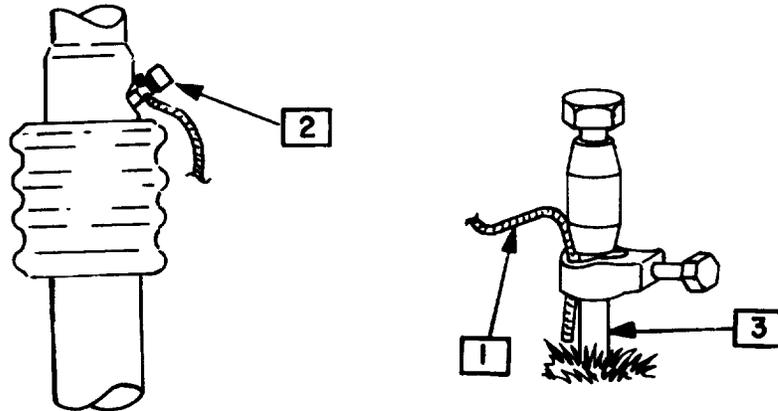

b. Disconnecting RF Cable. After making certain the radio operator has disconnected the antenna rf cable from the radio, disconnect the rf cable connector **1** from the balun **2** at the base of the antenna mast **3**. Coil and bind the one or two 100-foot rf cables used to connect the antenna to the radio. Replace the protector cap **4** on the connector **5** at the bottom of the balun.

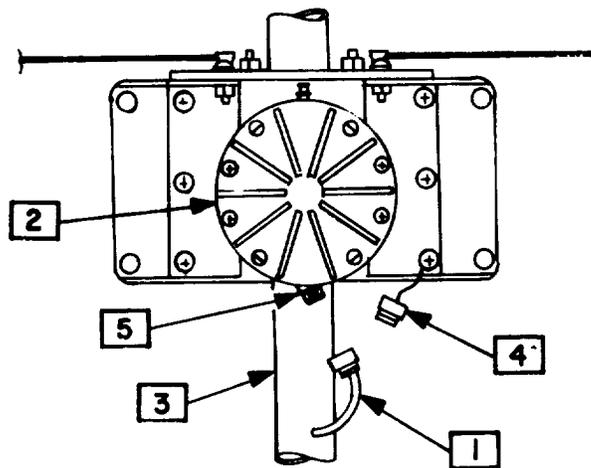

c. Disassembly of Safety Area Boundary.

- (1) Remove the eight caution plates and warning strips from the safety area rope.
- (2) Remove the lanyards from the four corner safety area rope stakes.
- (3) Remove the safety area rope from the safety area rope stakes and coil and bind the rope.
- (4) Pull the six safety area rope stakes from the ground and disassemble them.

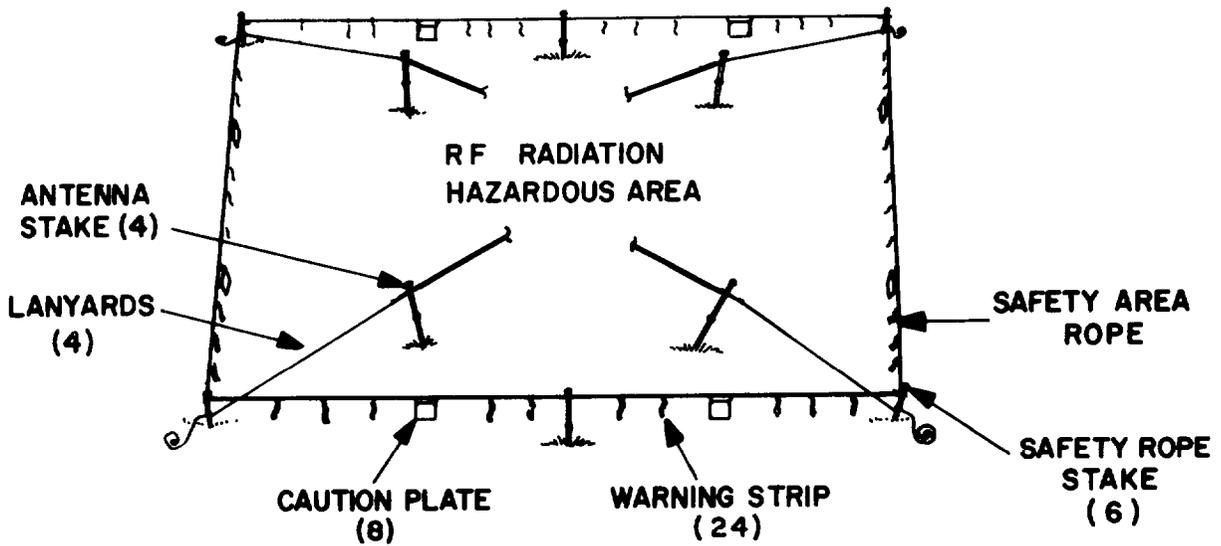

d. Disassembly of Double Delta Antenna.

- (1) Remove the warning strips from the antenna wires and disconnect the antenna wires **1** connected to the antenna wire connectors **2** on the balun **3**.

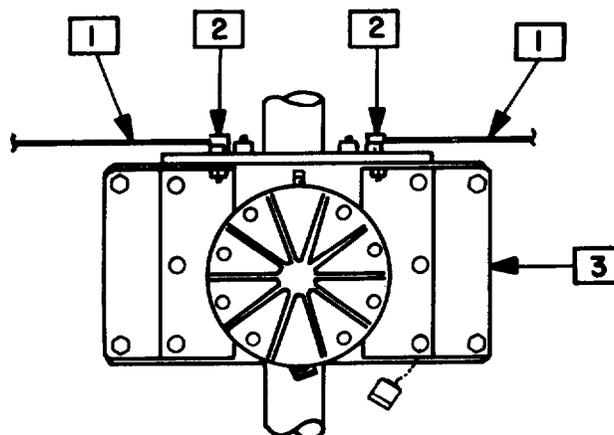

(2) Untie the loose end **1** of the halyard from the cleat **2** on the balloon clamp **3** and lower the terminating resistor box **4**. Disengage the slide hook **5** on the terminating resistor box **4** from the eyelet **6** on the halyard.

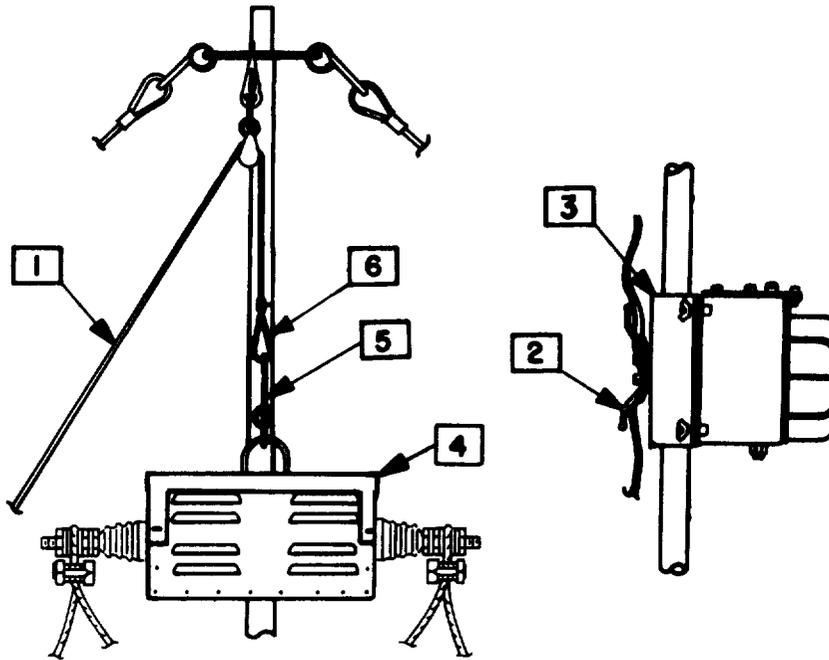

(3) Unsnap the snaphooks **1** on the four lanyards **2** and disconnect the antenna wire loops **3** from the four lanyards. Remove the three conductor splices **4** on each antenna wire **5**, and pull the antenna wire through the terminating resistor box connector. Coil and bind the antenna wires. Untie the four lanyards **2** from the four antenna stakes **6**. Remove and coil the lanyards. Remove the four antenna stakes from the ground, and separate the ground rods.

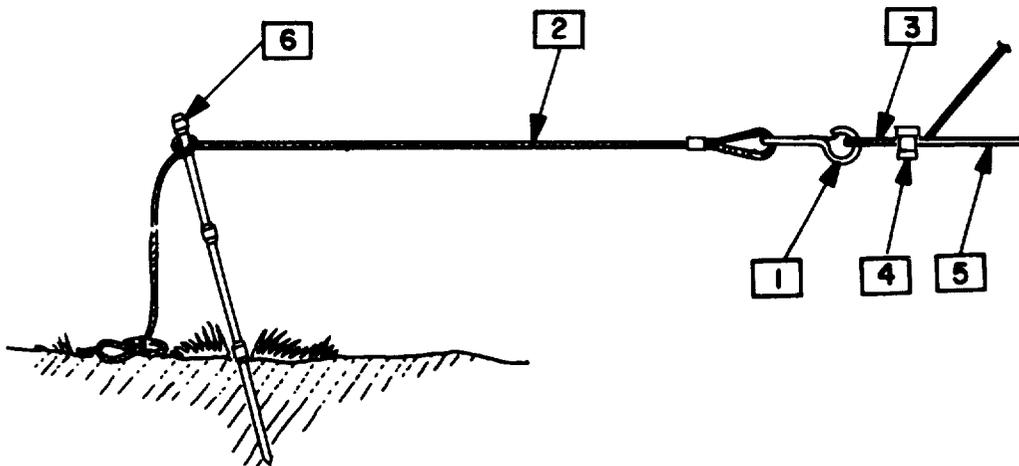

e. Removal of Balun from Mast. Remove the four wingnuts **1** and separate the balun **2** and the balun clamp **3** from the mast **4**. Replace the four wingnuts on the balun.

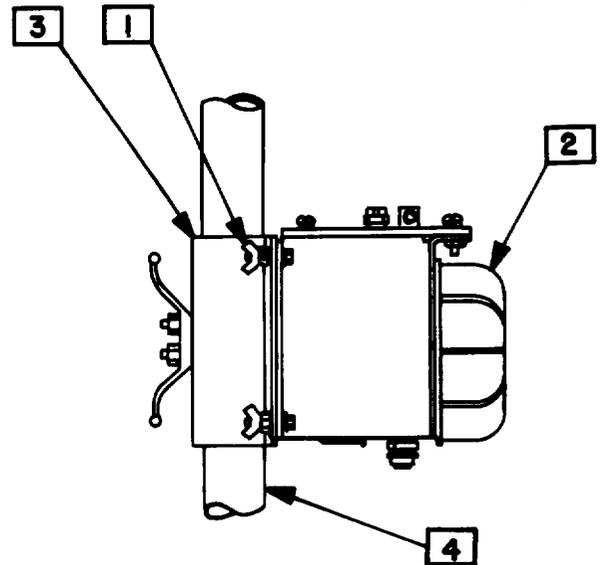

WARNING

Do not try to lower the mast without at least two persons. If the mast must be lowered when the ground is wet, frozen or slippery or the wind is blowing at a rate greater than 15 miles per hour (13 knots), at least four persons (two at each location) should be available.

f. Lowering the Mast.

(1) Two people are required to lower the mast. Person 1 stands near guy stake C **1** (guy stake away from which the mast base swivel will bend; see illustration on page 2-5). Person 2 stands near the mast base **2** on the side of the mast opposite person 1.

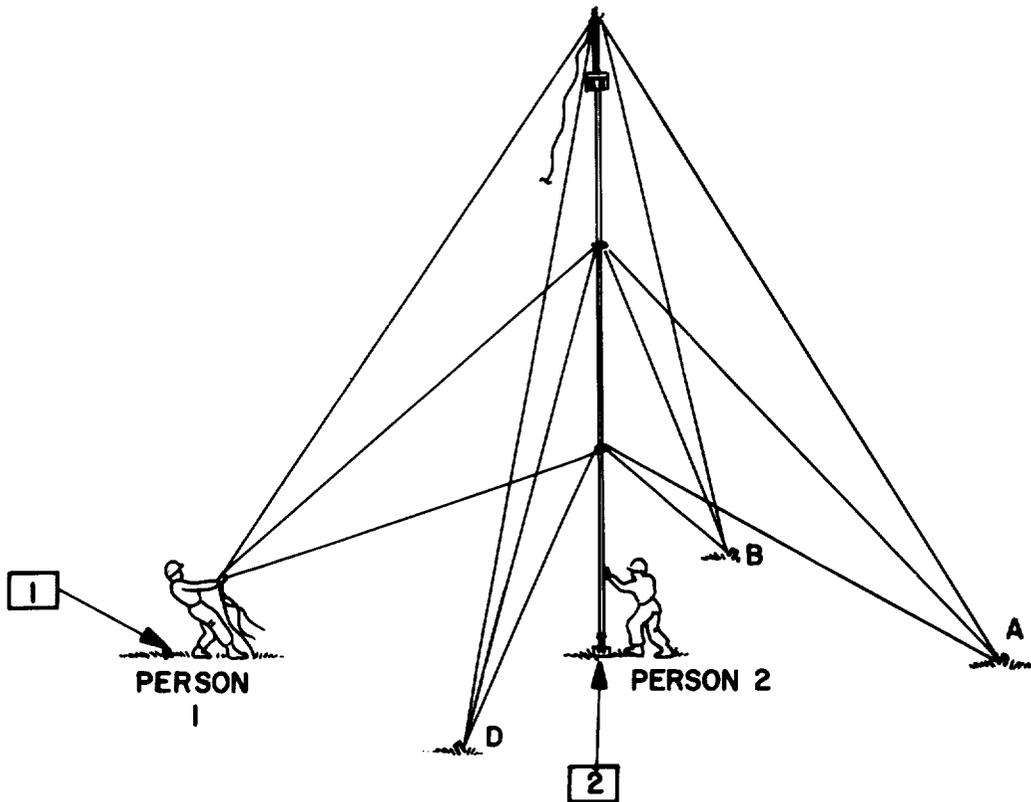

CAUTION

Before lowering the mast, make sure the mast base swivel is positioned so that it will hinge (bend) in the desired direction.

(2) Person 1 removes the three guys **1** from guy stake C **2** while person 2 supports the mast **3** from the opposite side. Person 1 holds all three guys **1** firmly and walks slowly toward the mast **5**. At the same time, person 2 walks backward slowly away from the mast and supports the mast **5** as it lowers to the ground.

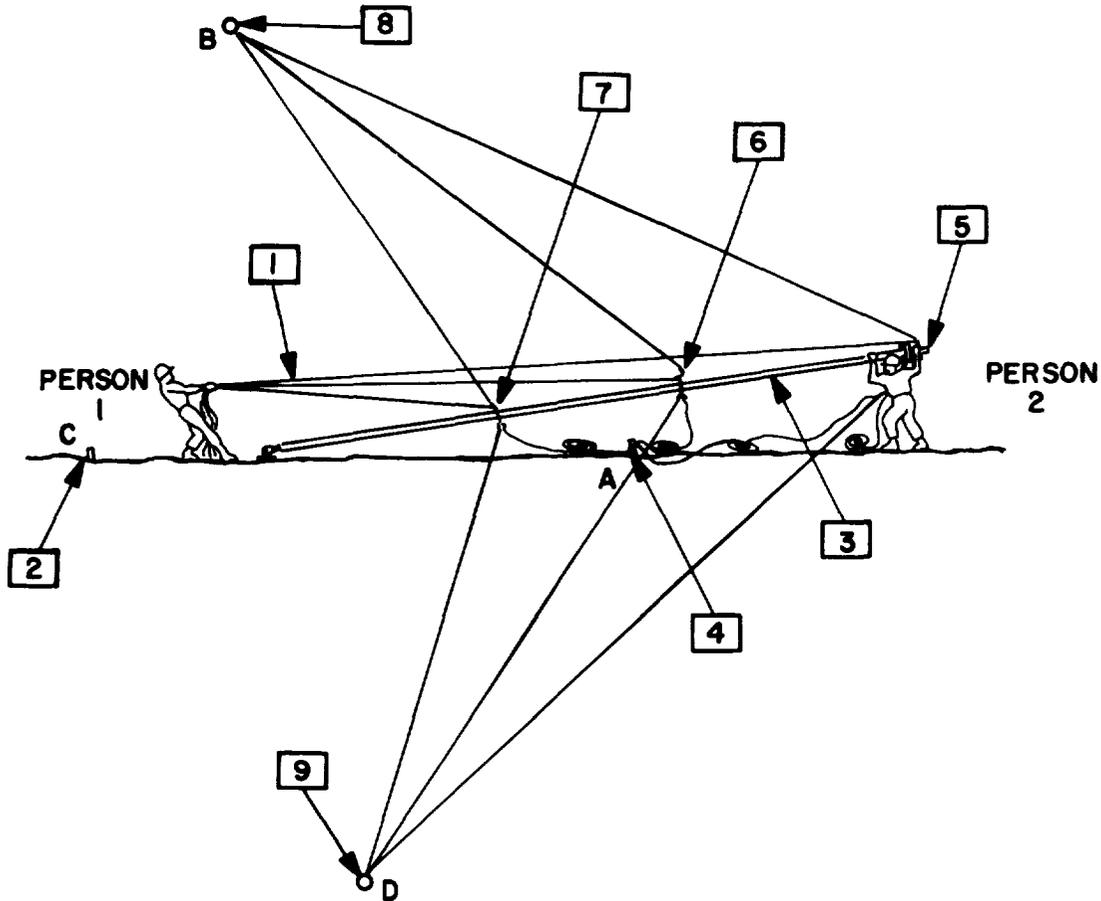

g. Removal of Guys, Guy Stakes, and Halyard.

(1) Disconnect the three guys from guy stake C to the top **5** center **6** and bottom **7** guy plates. Coil and bind the three guys **1**. Disconnect, coil and bind each of the three guys from ground stakes B **8**, D **9**, and A **4** to the top, center and bottom guy plates.

(2) Remove the four guy stakes from the ground.

(3) Disconnect the pulley snaphook **1** from the top guy plate **2**. Coil and bind the halyard **3**.

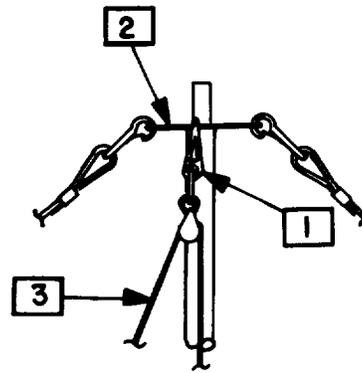

h. Removal of Terminating Resistor Stop.
 Remove the four wingnuts **1** and separate the terminating resistor stop **2** and terminating resistor stop clamp **3** from the mast **4**. Replace the four wingnuts **1** on the terminating resistor stop **2**.

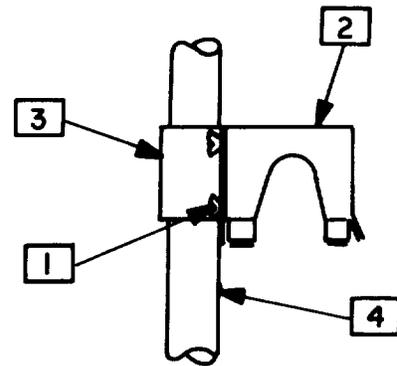

i. Disassembly of Mast.

- (1) Remove the insulator from the mast base. (See illustration on page 2-8).
- (2) Separate the 16 mast sections and the three guy plates.
- (3) Pull the mast base from the ground. Remove the support plate.

j. Packing Carrying Frame and Carrying Case. See section VI, chapter 4.

Section III. OPERATION UNDER UNUSUAL CONDITIONS

2-7. Sandy or Marshy Terrain.

If the ground in which the mast base, guy stakes, and antenna rods are to be inserted is sandy or marshy, get specific instructions from your supervisor on how to reinforce the mast base and stakes. The guy stakes may be reinforced by driving the four guy stakes into the ground at least 2 inches below the surface and burying the three guys connected to each guy stake in the ground.

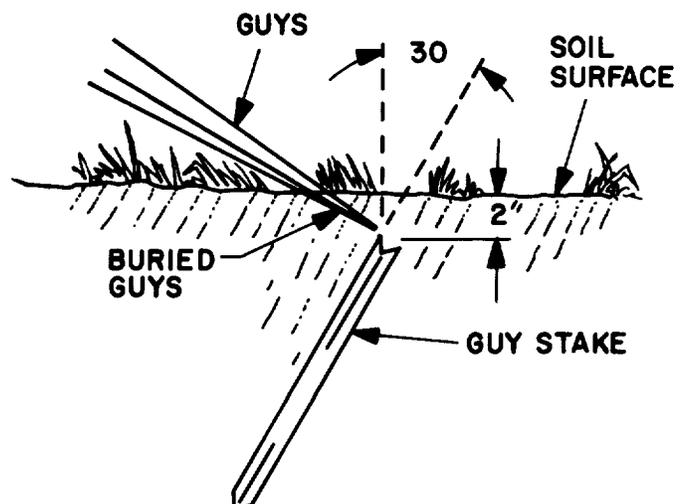

2-8. Strong Winds.

WARNING

Do not erect or tear down the antenna in winds exceeding 35 miles per hour (30 knots).

a. At least four persons (two at each location) must be available to erect or tear down the antenna in winds exceeding 15 miles per hour (13 knots).

b. When the antenna is installed in an area where strong winds are prevalent, get specific instructions from your supervisor regarding the reinforcement of mast base and stakes. Inspect the antenna at least twice daily. Make certain:

- The mast is straight and vertical.
- The guy stakes, mast base, antenna stakes and safety area rope stakes are firmly imbedded in the ground.
- The antenna wire and mast guys are secure and reasonably taut.

2-9. Snow and/or Ice.

WARNING

When the mast, guys and antenna wire become heavily iced, add a warning on each of the four sides of the safety area rope "BEWARE OF ICE".

a. At least four persons (two at each location) should be available to erect or teardown the antenna if the ground is wet, frozen, or slippery.

b. When the antenna is installed in a region known for heavy snow and icing conditions, inspect the antenna frequently, making certain the antenna wire and mast guys are secure and reasonably taut.

2-10. Extreme Cold. Extreme cold causes cables and wire to become hard and brittle and difficult to handle. Be careful when handling the rf cables and antenna wire so that kinks and unnecessary loops will not result in permanent damage.

2-11. Electrical Storms. Do not try to erect or teardown the antenna, raise or lower the antenna wire, or work on the antenna during an electrical storm or when an electrical storm is imminent.

CHAPTER 3

OPERATOR MAINTENANCE INSTRUCTIONS

Section I. LUBRICATION INSTRUCTIONS

3-1. No lubrication is required for the antenna.

Section II. TROUBLESHOOTING PROCEDURE

3-2. No operator/crew troubleshooting is authorized for the antenna. Any trouble or faults detected by you are to be reported to the organizational repair person. Corrective action will be taken by the next level of maintenance personnel.

3-3. Operator/Crew Maintenance. Operator/crew maintenance is limited to preventive maintenance checks and services. Refer to table 2-1.

CHAPTER 4

ORGANIZATIONAL MAINTENANCE

Section I. REPAIR PARTS, SPECIAL TOOLS, TMDE AND SUPPORT EQUIPMENT

4-1. Common Tools and Equipment. Common tools and equipment are listed in section III of the maintenance allocation chart (appx B).

4-2. Special Tools, TMDE and Support Equipment. No special tools are authorized for use at the organizational category. The TMDE and support equipment are listed in section III of the maintenance allocation chart (appx B).

4-3. Repair Parts. Repair parts authorized for organizational maintenance are listed and illustrated in the repair parts and special tools lists (appx F).

Section II. SERVICE UPON RECEIPT

4-4. Unpacking. The AS-3577/GRC is self contained in one carrying case that weighs 260 lbs (108 kg), is 4.125 feet long, 1.875 feet wide, and 1.5 feet deep (1.258 by 0.572 by 0.457 meters, respectively). The carrying case is equipped with four handles for lifting, and is shipped in a wooden box.

CAUTION

Be careful when unpacking to avoid damaging the equipment. Do not attempt to pry the cover, bottom, sides, or ends off wooden boxes. The equipment may be damaged.

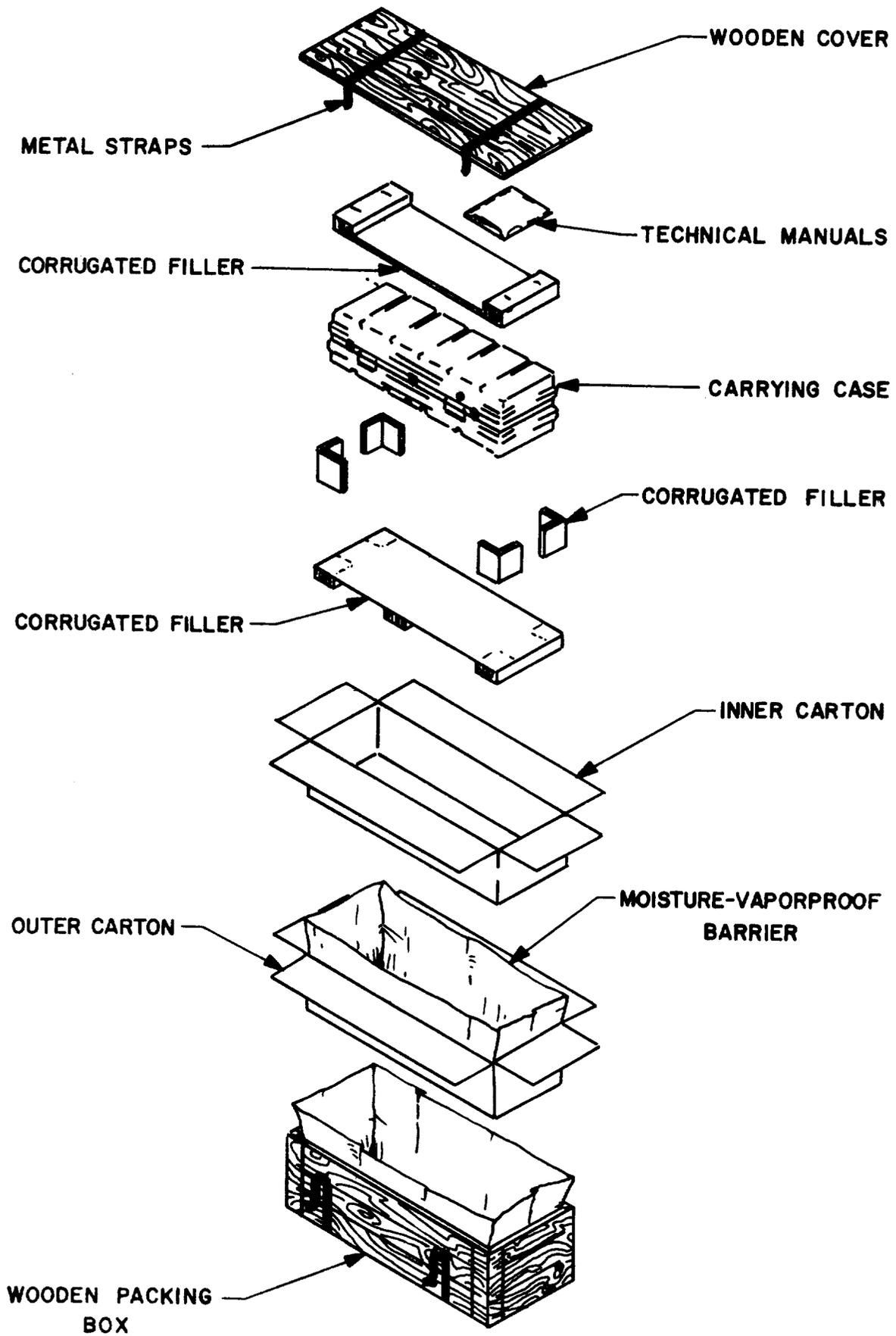

- a. Position the wooden box with the top facing up.
- b. Cut and fold back the metal straps.
- c. Use a nail puller to remove the nails from the cover and one side of the box.
- d. Open the moisture-vaporproof barrier that covers the outer carton.
- e. Open the outer carton and the moisture-vaporproof barrier covering the inner carton.
- f. Open the inner carton and remove the top and side corrugated filters.

WARNING

Four persons are required to lift the 260 lb. (108 kg) carrying case.

- g. Lift the carrying case from the inner carton.
- h. Save the boxes and packing materials.
- i. Open the carrying case and remove the contents. Unpack the carrying frame (para 4-5).

4-5. Unpacking Carrying Frame.

a. Unfasten the two straps that hold the three mast sections in the mast section rack on top of the carrying frame. Remove the three mast sections from the mast section rack. Remove all guys, stakes, and the two mast sections from the trough in the carrying frame.

NOTE

Components of the mast assembly, including the carrying frame, are listed in c, below.

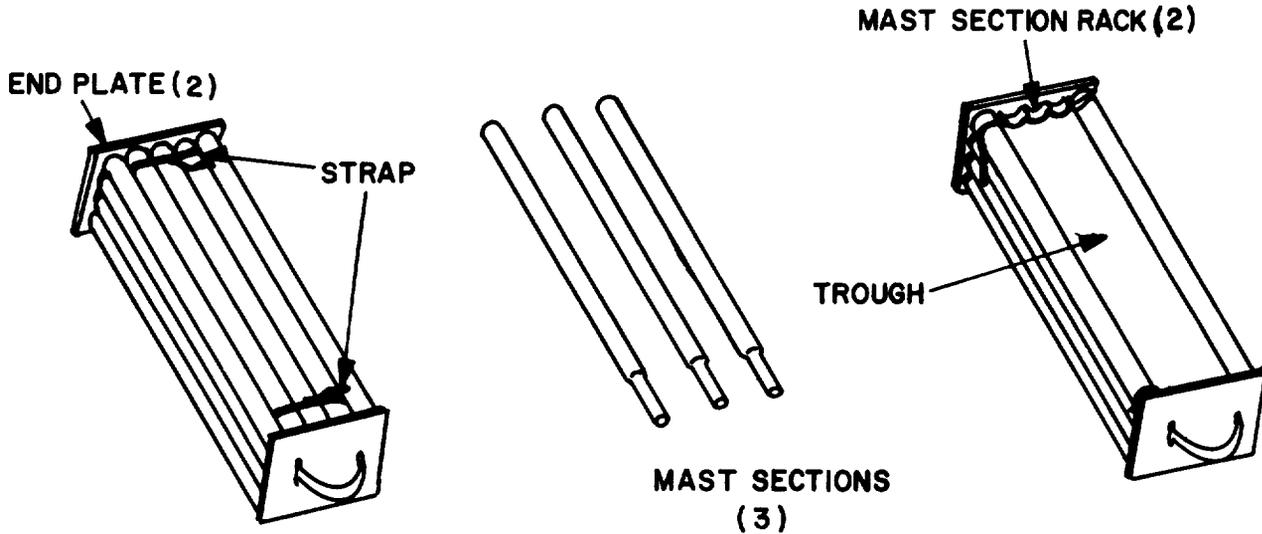

b. Loosen the turnbuckle on the cable holding the two end plates together. Unhook the cable and separate the two end plates from the 11 mast sections remaining on the perimeter of the end plates.

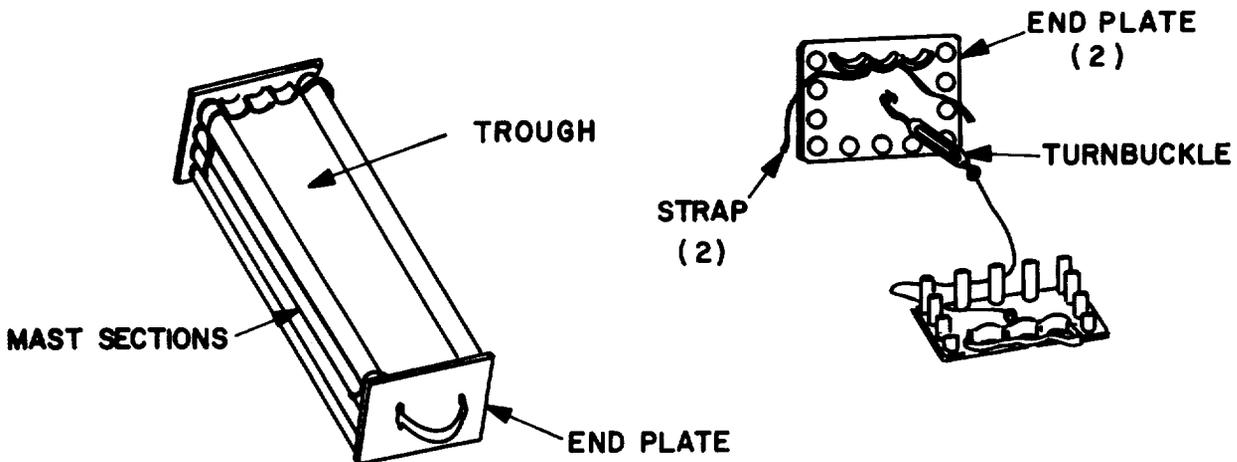

c. After unpacking the carrying frame, make sure that all of the mast assembly items, in the quantities listed below, are available.

<u>Quantity</u>	<u>Item</u>
1	Frame MX-1116/GRA-4
4	Guy MX-381A/GRA-4
4	Guy MX-382A/GRA-4
4	Guy MX-383A/GRA-4
5	Guy Plate MX-1470/U
5	Guy Stake GP-111/G
1	Hal yard MX-516/GRA-4
1	Hammer
1	Insulator MX-384/GRA-4
1	Mast Base AB-154/U
16	Mast Section AB-85/GRA-4
1	Plate (6-inch square)

4-6. Checking Unpacked Equipment.

a. Completeness. Check the equipment against the packing slip. Report all discrepancies in accordance with the instructions in DA Pam 738-750.

b. Damage. Inspect the components for damage incurred during shipment. If the equipment is damaged, report the damage on SF 364, Report of Discrepancy (ROD).

c. Modifications. Check to see whether the equipment has been modified. Equipment that has been modified will have the Modification Work Order (MWO) number near the nomenclature plate. Check also to see whether all currently applicable MWOs have been applied. Current MWOs applicable to the equipment are listed in DA Pam 310-1.

Section III. ORGANIZATIONAL PREVENTIVE MAINTENANCE CHECKS AND SERVICES (PMCS)

4-7. General. Organizational PMCS is performed as instructed in table 4-1 only on an erected antenna. 'Record all' defects found during the performance of PMCS and the steps taken to fix them on DA Form 2404, Equipment Inspection and Maintenance Worksheets. Instructions for reporting/correcting noted deficiencies are contained in DA Pam 738-750.

4-8. Organizational PMCS Procedures. Table 4-1 lists the PMCS which must be performed by organizational maintenance personnel.

a. Purpose. PMCS is done to ensure that the equipment is ready for use at all times. These checks and services help you find and fix defects before the equipment is damaged or fails.

b. Item No. Column. Numbers in the first column indicate the order in which things are to be done. Use the Item No. column to get the numbers for the TM Item No. column of DA Form 2404.

c. Interval Columns. The three interval columns (D, W, and M) indicate when to perform the checks. For example, a dot (•) in the W column indicates that the item listed on the same line in the next column should be checked weekly.

d. Item to be Inspected/Procedure Column.

(1) Item to be Inspected. The item to be inspected is described and illustrated.

(2) Procedure. The procedure by which the check is performed and results are described.

e. Equipment Not Ready/Available if Column. The criteria that will cause the equipment to be classified as not ready/available for readiness purposes are described.

Table 4-1. Organizational Preventive Maintenance Checks and Services

NOTE

Advise the radio operator prior to and after performing PMCS.

D - Daily

w - Weekly

M - Monthly

Item No.	Interval D W M	Item to be Inspected Procedure	Equipment Not Ready/Available If:
1	•	<p style="text-align: center;"><u>WARNING</u></p> <p>If the antenna is connected to a transmitter, make certain the transmitter is not transmitting and will not be "turned on" prior to entering the area bounded by the safety area rope.</p> <p><u>Installation.</u> Check that the antenna is properly installed (para 2-5).</p>	
2	•	<p><u>Ropes.</u> Check the 12 guys 1 halyard 2, safety area rope 3 and lanyards 4 for damage such as cuts, frays, and for strain. Observe their general appearance for serviceability. Replace unserviceable ropes.</p>	Ropes frayed, cut, or sagging.

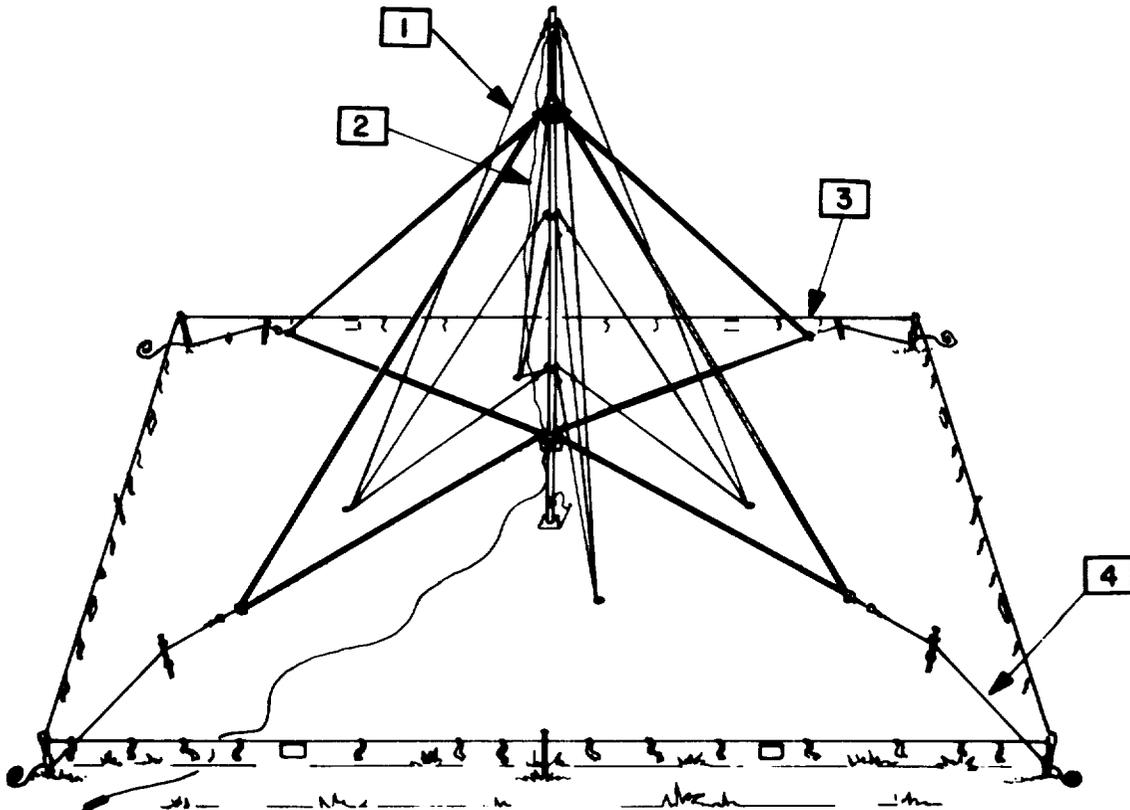

Table 4-1. Organizational Preventive Maintenance Checks and Services - Continued

D - Daily

W - Weekly

M - Monthly

Item No.	Interval			Item to be Inspected Procedure	Equipment Not Ready/Available If:
	D	W	M		
3		•		<p><u>Mounting hardware.</u> Check the bolts, washers, wingnuts 1 and clamps 2 securing the balun 3 to the mast 4 to assure they are clean, intact, and not loose fitting. Tighten, or replace.</p>	Bolts, wingnuts, or clamps loose or dirty.
4		•		<p><u>Rf cable connector, balun, and antenna wire connectors.</u> Insure that the rf cable 5 and antenna wire connections 6 at the balun are clean, intact, and not loose fitting. Clean, tighten connectors.</p>	
5		•		<p><u>Terminating resistor box connectors and antenna wire.</u> Untie the halyard 7 from the cleat 8 on the balun 3 and lower the terminating resistor box to the ground.</p>	

Table 4-1. Organizational Preventive Maintenance Checks and Services - Continued

D - Daily

W - Weekly

M - Monthly

Item No.	Interval			Item to be Inspected Procedure	Equipment Not Ready/Available If:
	D	W	M		
				Ensure that the antenna wire 1 and conductor splices 2 at the terminating resistor box 3 are clean, intact and not loose. Clean and tighten connector splices 2 .	Connections loose or dirty.

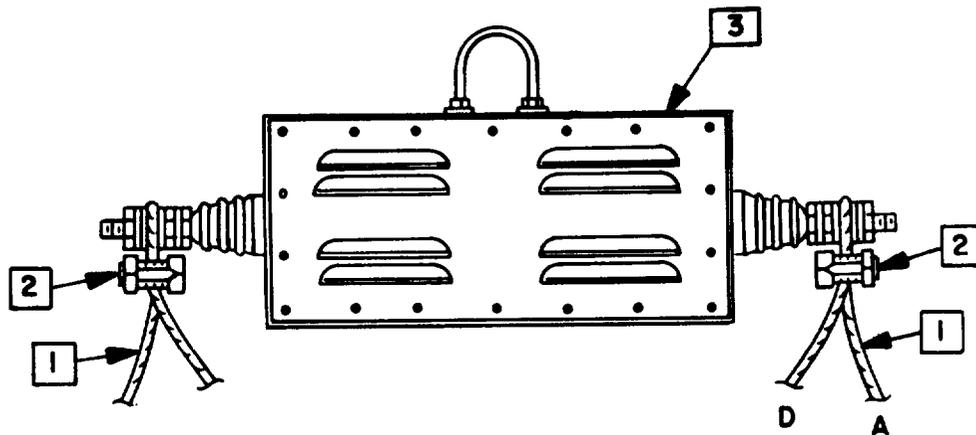

--	--	--

Check the two 220-foot lengths of antenna wire **1** for damage such as cuts, frays and strain. Replace the antenna wire if it appears not to be serviceable (para 4-16). Check the tightness of the three conductor splices **2** on each of the two pieces of antenna wire. Tighten or replace.

Antenna wire has cuts, frays, and strain. Conductor splices are loose.

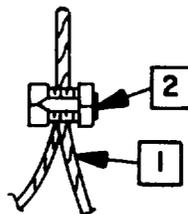
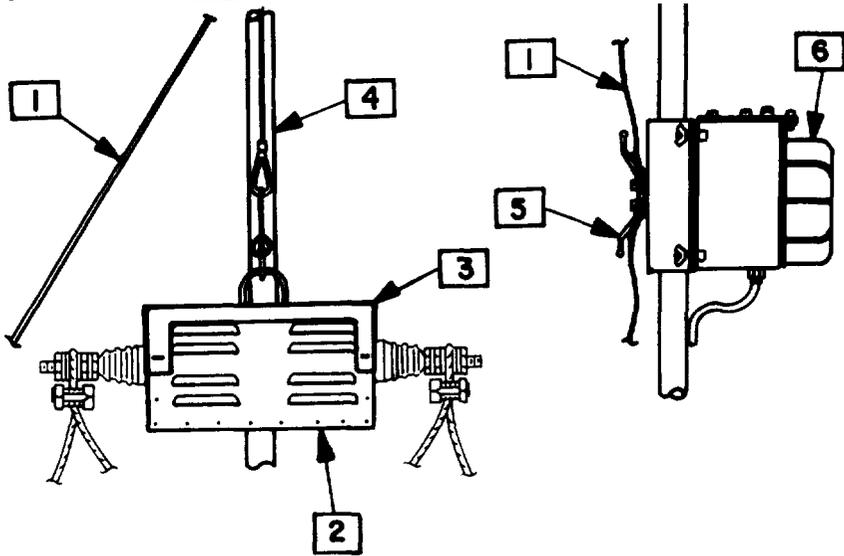

Table 4-1. Organizational Preventive Maintenance Checks and Services - Continued

D - Daily

W - Weekly

M - Monthly

Item No.	Interval			Item to be Inspected Procedure	Equipment Not Ready/Available If:
	D	W	M		
				<p>Being careful not to tangle the antenna wires and the guys, use the halyard 1 to raise the terminating resistor box 2 to the stop 3 on the mast 4 and tie the halyard 1 to the cleat 5 on the balun 6.</p> 	
6				<ul style="list-style-type: none"> • <u>Modifications.</u> Check DA Pam 310-1 for the publication of new applicable MWOs. Urgent MWOs must be applied immediately, normal MWOs must be scheduled. 	An urgent MWO not applied.
7				<ul style="list-style-type: none"> • <u>Preservation.</u> Check all accessible metal surfaces for corrosion, rust and moisture. Remove corrosion, rust and moisture and spot paint bare spots (para 4-18). 	
8				<ul style="list-style-type: none"> • <u>Publications.</u> Check DA Pam 310-1 to see that all publications are available, complete, serviceable and current. 	

Section IV. PRINCIPLES OF OPERATION

4-9. General. The AS-3577/GRC permits transmission or reception of rf energy in the 2-30 MHz frequency range. It is an omnidirectional, broad band, double delta antenna that can receive or transmit rf signals over a distance up to 380 miles. When used for transmission, it can handle power up to a maximum of 1 kilowatt.

4-10. Circuit Description. Refer to the schematic diagram below. The letters A, B, C, and D are terminal designations assigned during installation (para 2-5). They are not equipment markings. During reception or transmission, rf energy is conducted to or from the receiver or the transmitter, respectively, through the coaxial rf cable(s). The rf cable(s) is connected to the balun. The balun transformer matches the 50-ohm impedance of the rf cable to the 600-ohm input impedance of the antenna. The antenna radiating and receiving device is formed by wires configured into two delta arrangements. As configured, one half of one continuous antenna wire, and one half of the other continuous antenna wire form one delta, and the remaining halves form the other delta. The peaks of the two deltas are connected to the 600-ohm terminating resistor box.

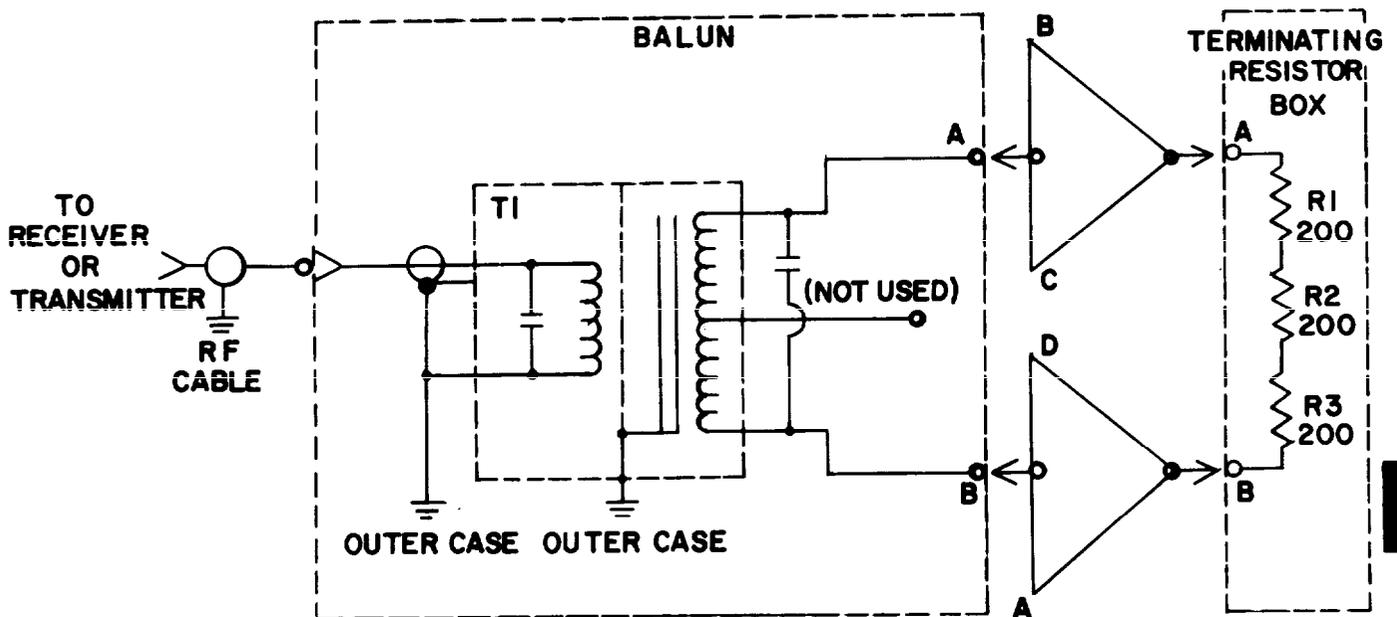

ANTENNA AS-3577/GRC SCHEMATIC DIAGRAM

Section V. ORGANIZATIONAL TROUBLESHOOTING

4-11. General. Troubleshooting at the organizational category is limited to visual checks and the use of a multimeter to isolate faults to the terminating resistor box, the balun, antenna wire, and electrical cables.

4-12. Troubleshooting Table. The malfunctions listed in table 4-2 can show up during operation of the radio, during scheduled PMCS (tables 2-1 and 4-1), during assembly and preparation for use (para 2-5), during preparation for movement (para 2-6) or during corrective maintenance.

Table 4-2. Organizational Troubleshooting

Malfunction	Test or Inspection	Corrective Action
-------------	--------------------	-------------------

WARNING

If the antenna is connected to a transmitter, make sure the transmitter is not transmitting and will not be turned on prior to disconnecting or connecting the rf cable and/or entering the area bounded by the safety area rope.

1. WEAK OR NO RECEPTION AT THE RECEIVER.

Step 1. Make sure the rf cable is neither disconnected nor broken.

- Connect the rf cable.
- Replace the rf cable.

Step 2. Disconnect the rf cable **1** from the rf connector **2** on the balun **3**. Use the multimeter to measure the resistance between the inner conductor of the rf connector **2** to the outer case (bare spot) of the balun **3**. The reading should be less than one ohm.

If normal, go to step 3.
If abnormal, replace the balun (para 4-15).

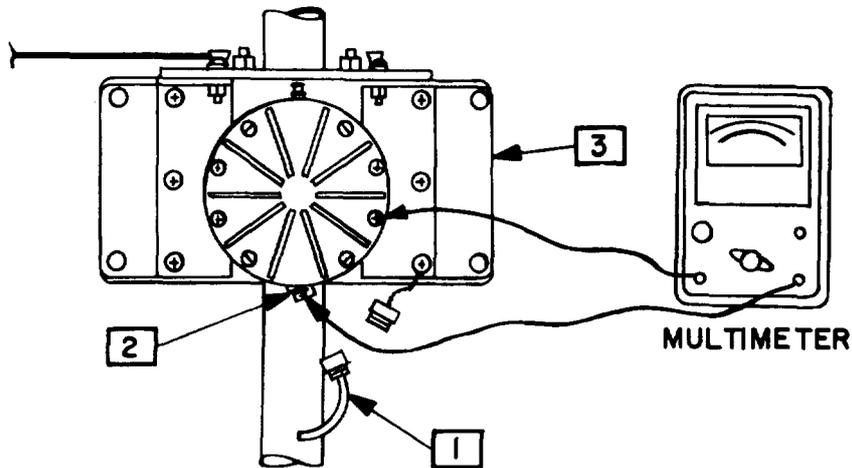
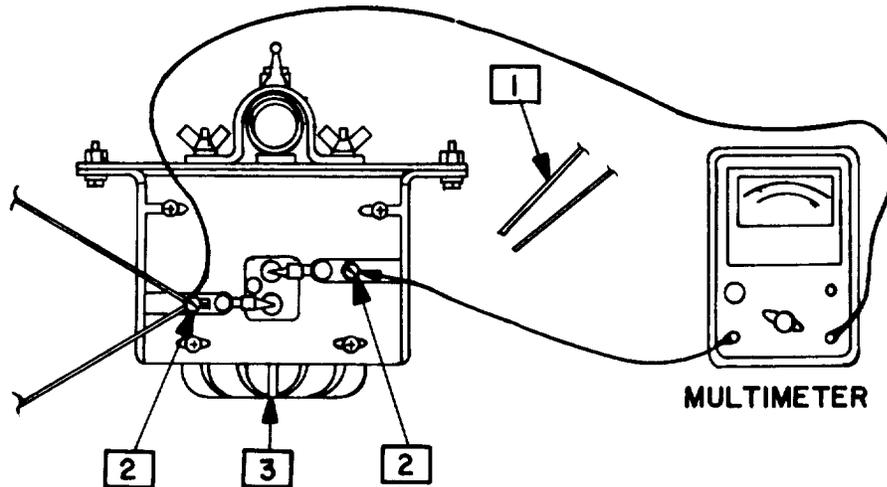

Table 4-2. Organizational Troubleshooting - Continued

Malfunction	Test or Inspection	Corrective Action
-------------	--------------------	-------------------

Step 3. Disconnect the antenna wire **1** from one antenna connector **2** on the balun **3**. Use the multimeter to measure the resistance between the two antenna connectors **2**. Reading should be less than 1 ohm.

If normal, go to step 4.
 If abnormal, replace the balun (para 4-15).



Step 4. Use the multimeter to measure the resistance between either antenna connector **1** and the outer shell of the rf cable connector **2**. Reading should be infinite (open circuit).

If normal, go to step 5.
 If abnormal, replace the balun (para 4-15).

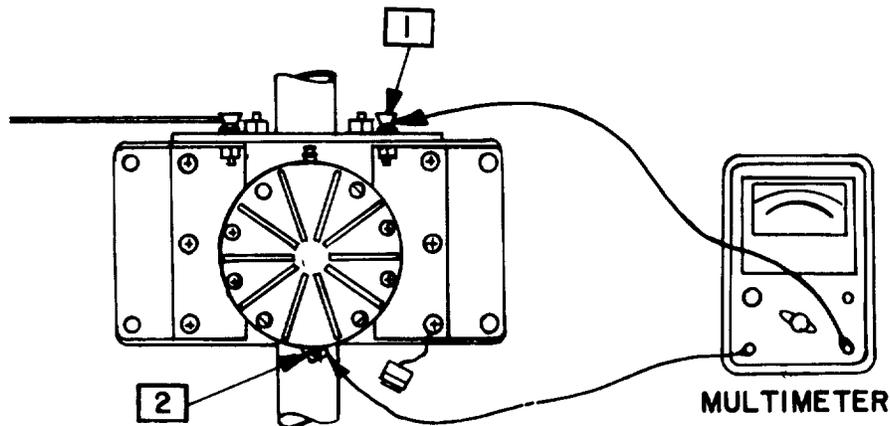
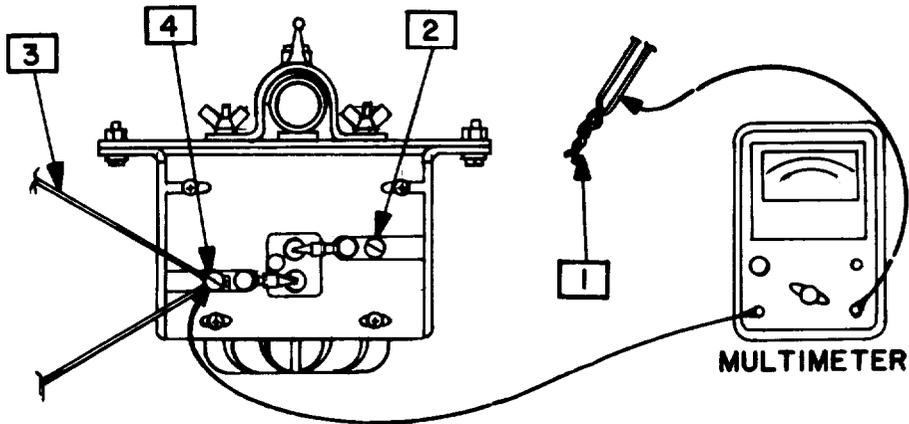

Table 4-2. Organizational Troubleshooting - Continued

Malfunction	Test or Inspection	Corrective Action
-------------	--------------------	-------------------

Step 5. Use the multimeter to measure the resistance between the two antenna wires **1** (removed from one antenna connector **2** on the balun and the two antenna wires **3** (not removed) from the other connector **4** of the balun. Normal reading is 600 ohms.

If normal, go to step 6.
 If abnormal, go to step 7.



Step 5. Check for continuity of each of the two antenna wires **1**. That is, use the multimeter to check for continuity (less than 1 ohm) between the two ends of the antenna wire removed from one antenna connector **2**. Repeat the measurement for the antenna wires connected to the other connector **3**, after disconnecting the wires.

If normal, reconnect the rf cable and antenna wires.
 If abnormal, replace both antenna wires (para 4-16).

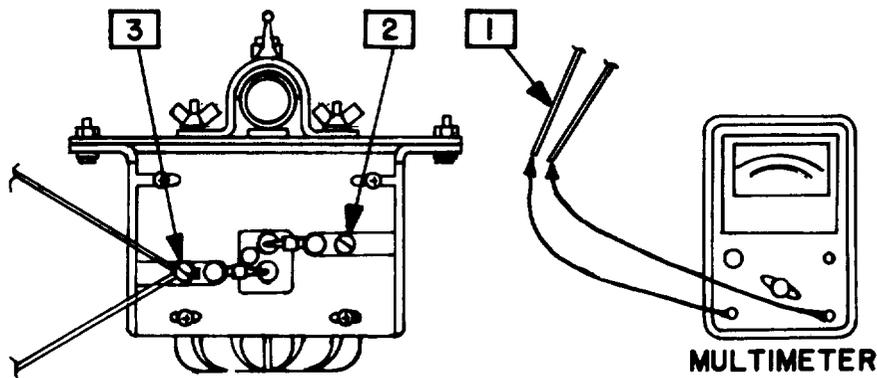

Table 4-2. Organizational Troubleshooting - Continued

Malfunction	Test or Inspection	Corrective Action
-------------	--------------------	-------------------

NOTE

Do not perform step 7 if the reading in step 5 was normal.

Step 7. Untie the halyard **1** from the cleat **2** on the balun **3** and lower the terminating resistor box **4** to the base of the mast. (Make sure the antenna wire loose ends are disconnected from the connectors on top of the balun and the two separate antenna wires are not making contact.) Measure the resistance between the two antenna connectors on the terminating resistor box **5**. Reading should be 600 ohms.

If normal, raise the terminating resistor box with the halyard **1**, and tie the loose end of the halyard to the balun cleat **2**. Reconnect the antenna wire loose ends to the balun. If abnormal, repair and replace the terminating resistor box (para 4-14).

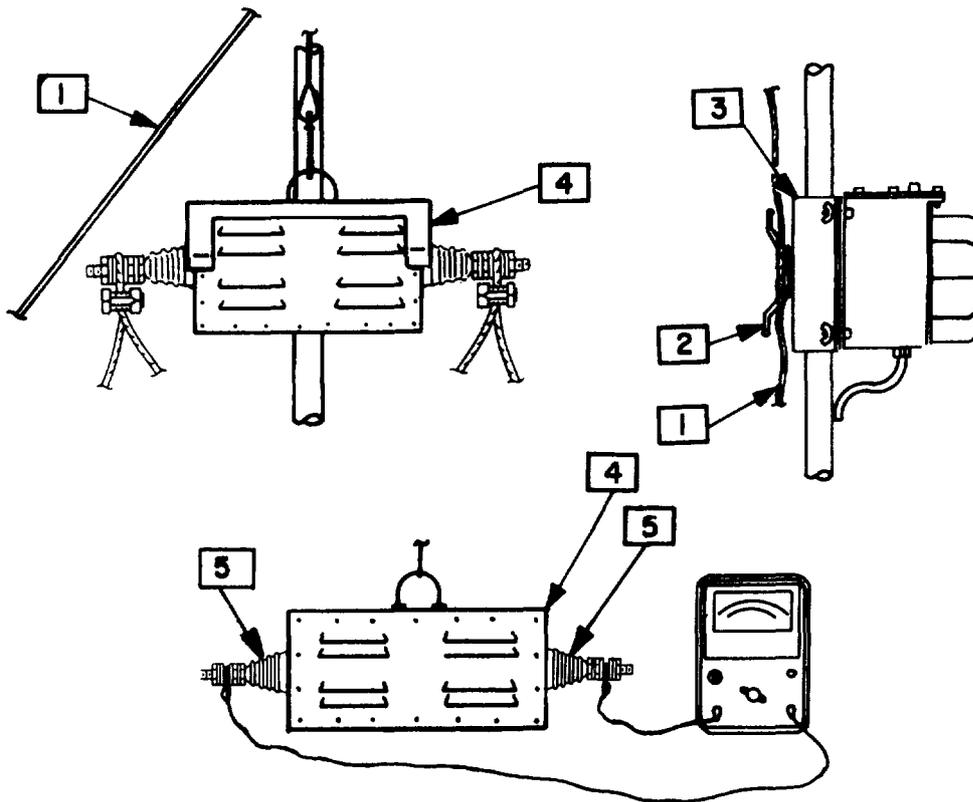

2. FAULTY TRANSMISSION. Repeat steps 1 through 7 above.

SECTION VI ORGANIZATIONAL MAINTENANCE PROCEDURES

4-13. General. This section covers the removal and replacement of components which you determined to be faulty during troubleshooting (table 4-2) or which you observed to be damaged during performance of PMCS (table 4-1).

4-14 Removal, Repair, and Replacement of Terminating Resistor Box.

WARNING

If the antenna is connected to a transmitter, make certain the radio operator has disconnected the antenna rf cable from the transmitter before entering the roped-off radiation hazardous area to replace the terminating resistor box.

a. Removal.

(1) After making certain the radio operator has disconnected the antenna rf cable from the radio, disconnect the antenna wires **1** from the top of the balun **2**.

(2) Unsnap the end loops of the antenna wire from the four lanyards that connect to the antenna stakes, and remove the four conductor splices (para 4-16).

(3) Untie the halyard **3** from the cleat **4** on the balun **2** and lower the terminating resistor box **5** to the base of the mast **6**.

(4) Disengage the slide hook **7** from the eyelet on the halyard **3**.

(5) Disconnect the antenna wires **1** from the antenna connectors **8** on each side of the terminating resistor box, by removing the conductor splice **9** from each antenna wire and pulling the antenna wires through the terminating resistor box connectors **8**.

b. Repair.

(1) Remove the 20 screws **10** that hold the front plate **11** to the terminating resistor box **5**. Using the multimeter measure the resistance of each power resistor **12**. The correct reading is 200 ohms.

(2) If defective, pull out the defective resistor(s) **12**; replace with a known good resistor(s).

(3) Check the resistance between the outer connectors **13**. The correct reading is 600 ohms.

(4) Replace the front plate **11** with the 20 screws **10**.

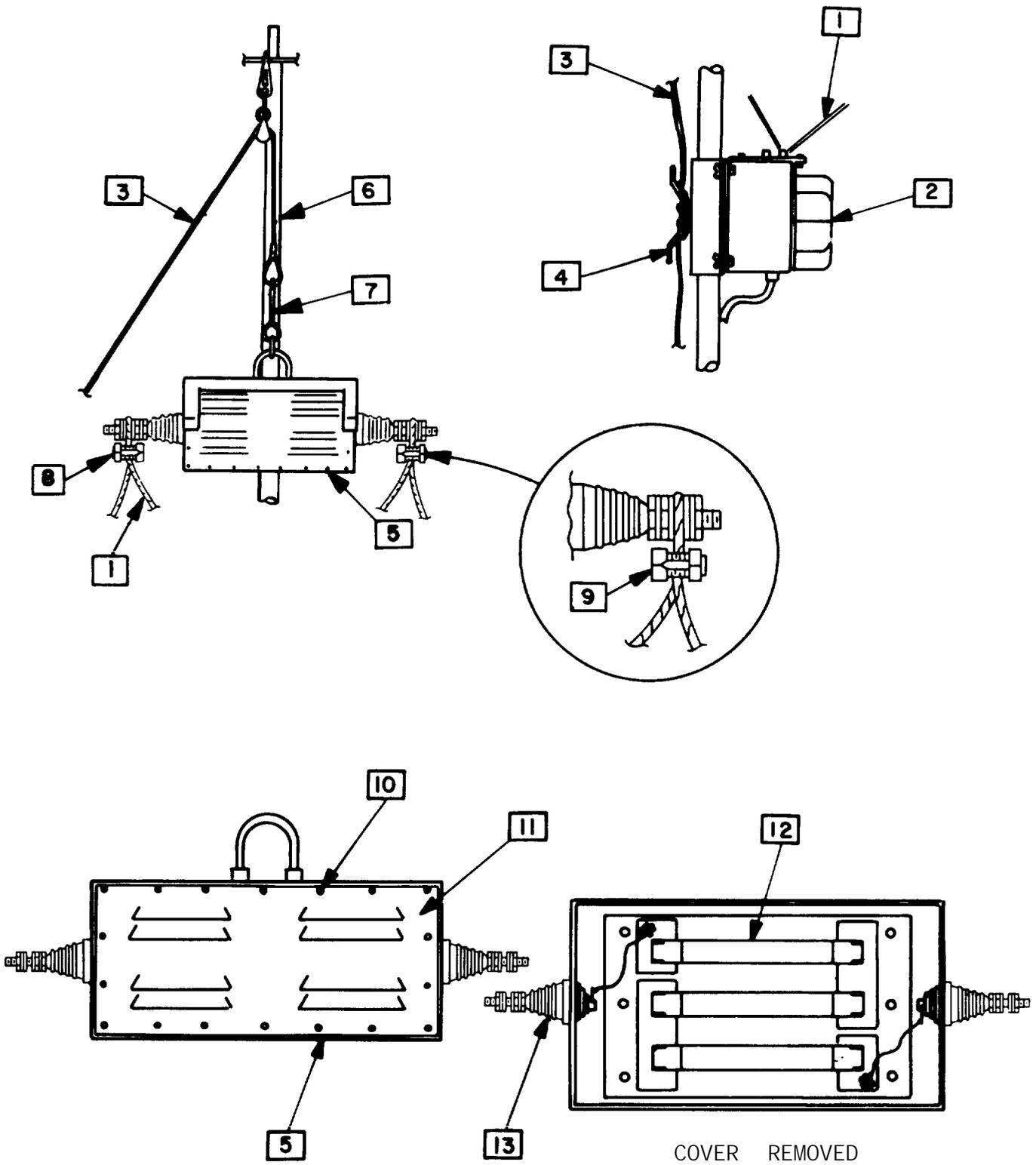

c. Replacement.

(1) Wrap each antenna wire **1** at the midpoint around each terminating resistor box connector **2** on each side of the terminating resistor box **3**.

(2) Place and tighten a conductor splice **4** on the antenna wires **1** coming from each terminating resistor box connector **2**.

(3) Replace the conductor splices forming the antenna loops that attach the antenna wire to the four antenna stake lanyards (para 4-16).

(4) Engage the slide hook **5** on top of the terminating resistor box to the eyellet on the halyard **6**.

(5) Using the halyard **6**, raise the terminating resistor box **3** on the mast **7** until the terminating resistor box **3** reaches the terminating resistor box stop **8**.

(6) Tie the loose end of the halyard **6** to the cleat **9** on the balun clamp **10**.

(7) Connect the loose ends of the antenna wire to the balun (para 4-15b(2)).

(8) Connect the antenna wire end loops, formed with the conductor splices, to the antenna stake lanyards (para 4-16b(6)).

(9) Notify the radio operator to reconnect the antenna rf cable to the radio.

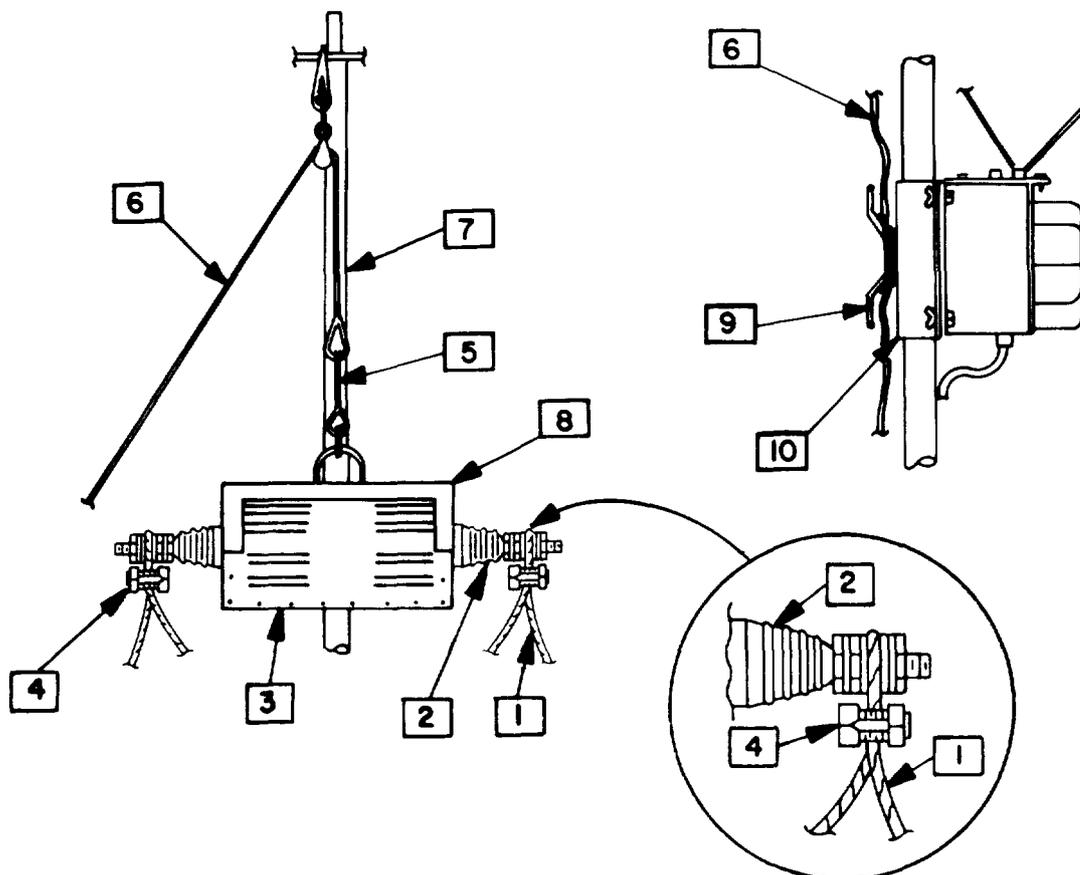

4-15. Removal and Replacement of Balun.

WARNING

If the antenna is connected to a transmitter, make certain the radio operator has disconnected the antenna rf cable from the transmitter before entering the roped-off radiation hazardous area to replace the balun.

a. Removal.

- (1) After making certain the radio operator has disconnected the antenna rf cable from the radio, disconnect the rf cable connector **1** from the balun connector **2** on the balun **3** at the base of the antenna mast **4**.
- (2) Disconnect the antenna wires **5** connected to the antenna wire connectors **6** on top of the balun **3**.
- (3) Remove and retain the four wingnuts **7** and separate the balun **3** and balun clamp **8** from the mast **4**.

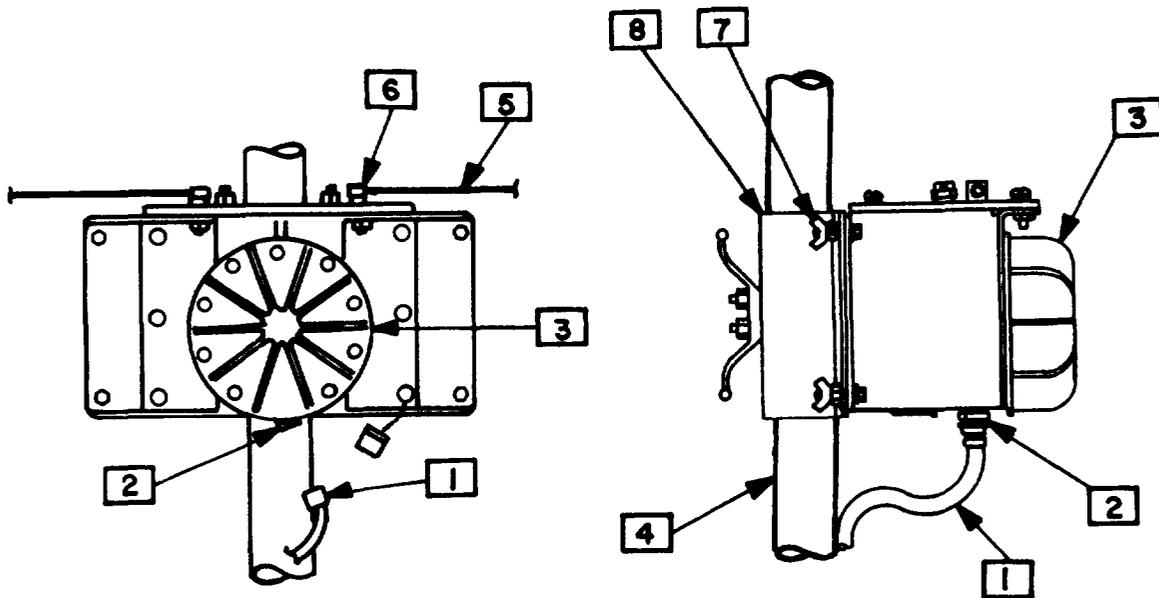
b. Replacement.

- (1) Place the balun clamp **8** and balun **3** on the mast **4**; replace the four wingnuts **7** securing the balun to the mast **4** and balun clamp. Before tightening the wingnuts **7** slide the balun and balun clamp up or down the mast until the balun is 6.5 feet from ground level. Secure the four wingnuts **7**.
- (2) Connect the antenna wires **5** to the antenna wire connectors **6** on top of the balun.
- (3) Connect the cable connector **1** to the rf connector **2** on the balun.
- (4) Notify the radio operator to reconnect the antenna rf cable to the radio.

4-16. Removal and Replacement of Antenna Wire. If one antenna wire is worn, frayed or broken, both should be replaced. The instructions in a and b below cover removal and replacement of both 220-foot pieces of antenna wire.

WARNING

If the antenna is connected to a radio, make certain the radio operator has disconnected the antenna rf cable from the radio before entering the roped-off rf radiation hazardous area to replace the antenna wire.

a. Removal.

(1) After making certain the radio operator has disconnected the antenna rf cable from the radio, disconnect the two antenna wires **1** connected to the antenna connector **2** on the balun **3**.

(2) Untie the lanyard **4** from the cleat **5** on the balun and lower the terminating resistor box **6** to the base of the mast.

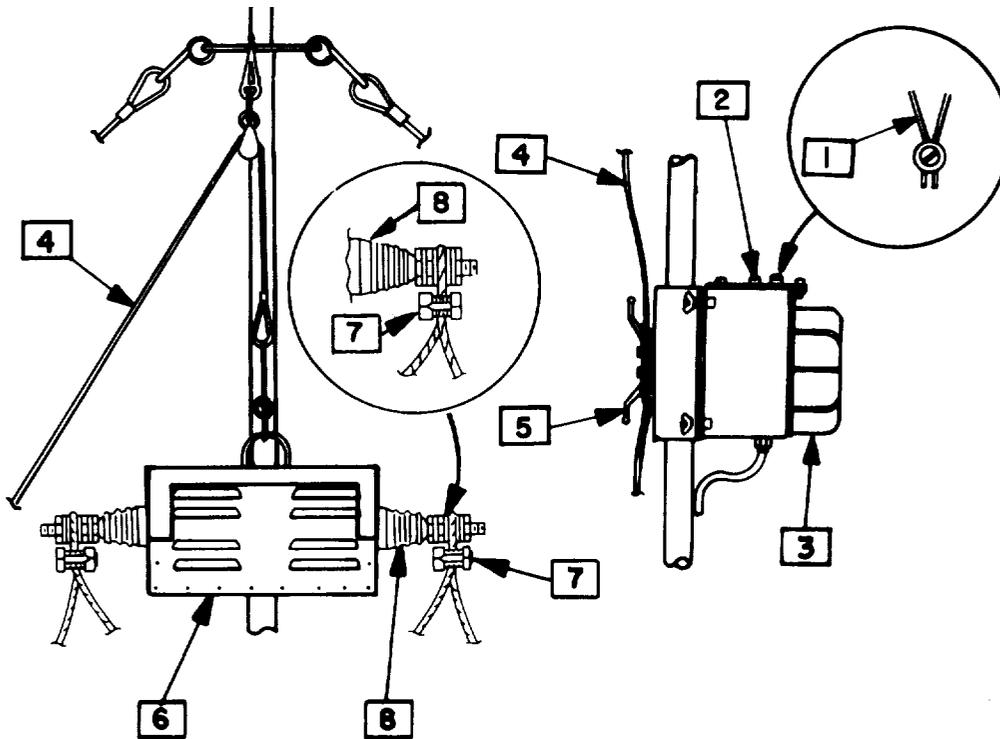

(3) Disconnect the antenna wire Loops from the snaphooks on the four lanyards connected to antenna stakes A, B, C and D (para b(6) below). Remove the four conductor splices at the lanyards.

(4) Remove the two conductor splices **7** from the antenna wires connected to the terminating resistor box connectors **8**. Remove the antenna wires from the terminating resistor box **8**.

b. Replacement.

(1) Cut two 220-foot pieces of antenna wire from the 500-foot roll.

(2) Wrap one antenna wire at the midpoint (110 feet from each end) around antenna connector **1** on the terminating resistor box **2** (terminal A will hold the antenna wire going to antenna stakes B and C) (para 2-5e)). Place and tighten a conductor splice **3** at the midpoint.

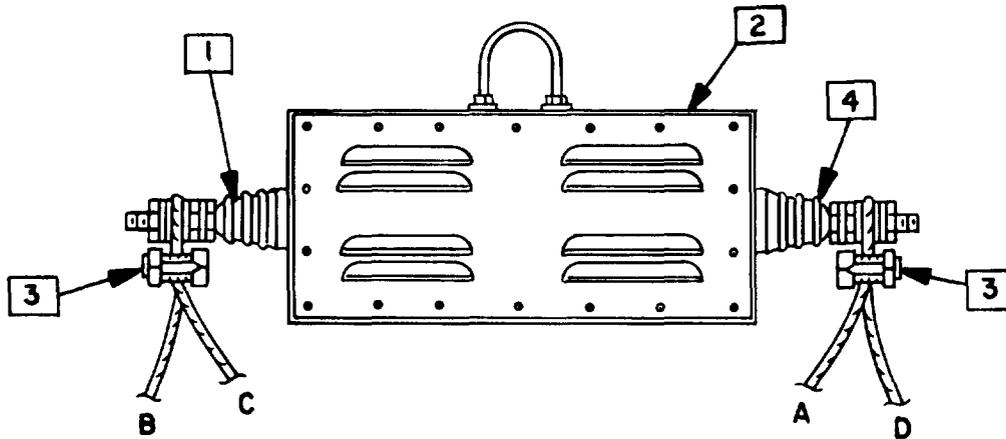

(3) Measure 60 feet from the midpoint of each loose end of the antenna wire, make a loop, and place a conductor splice at each point. These loops will connect to the snap hooks on the lanyards attached to antenna stakes B and C ((6) below).

(4) Repeat the procedures ((2) and (3) above) for the antenna wire to be connected to terminating resistor box connector **4** (terminal B will hold the antenna wire going to antenna stakes A and D (para 2-5e)).

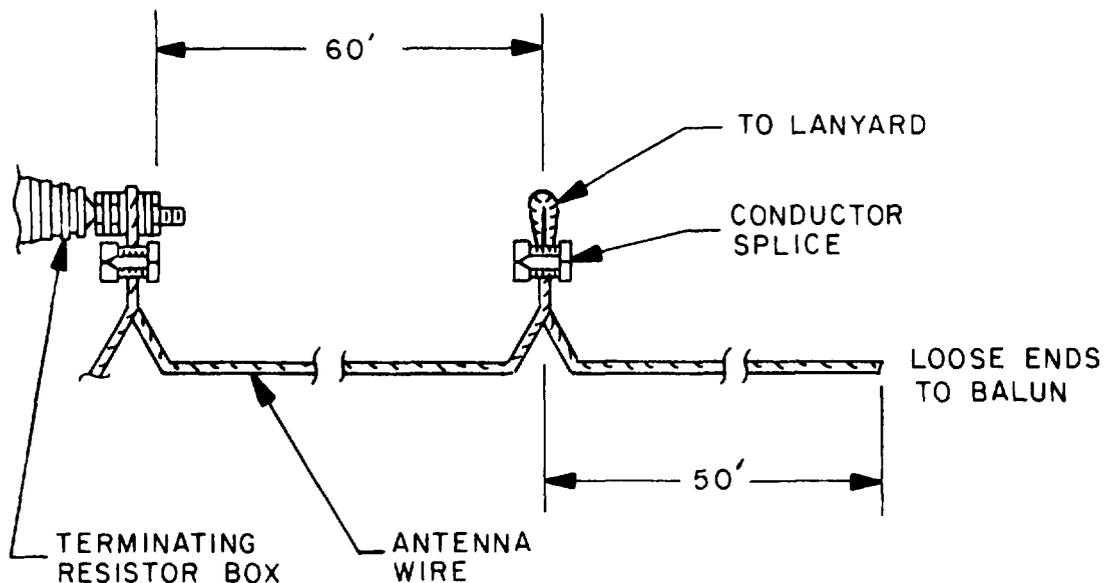

WARNING

Do not try to raise the terminating resistor box to the top of the mast during an electrical storm.

(5) Attach the slide hook **1** on the terminating resistor box **2** to the eyelet **3** on the halyard **4**. Pull the loose end of the halyard **4** to raise the terminating resistor box **2** until it reaches the terminating resistor stop **5**. Make sure the antenna wires are located between the middle and top guys. Tie the loose end of the halyard **4** to the cleat **6** on the balun clamp **7** which mounts the balun **8** to the mast.

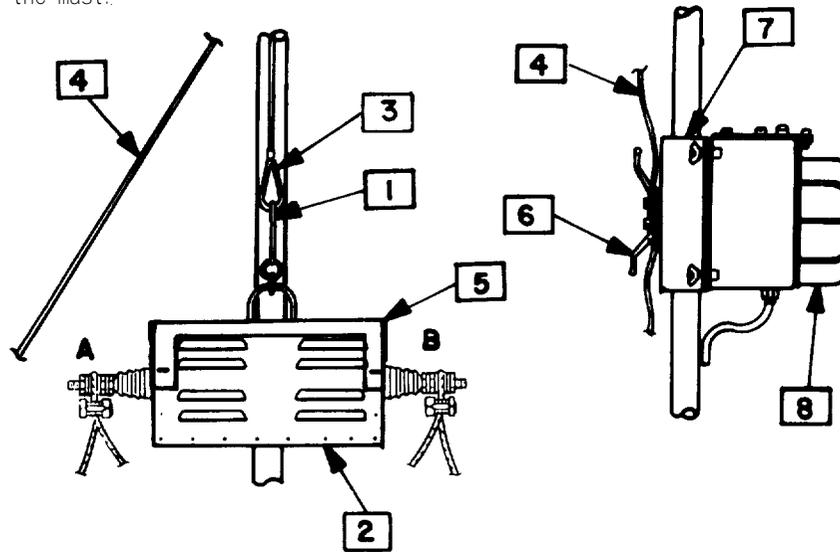

(6) Attach one of the end loops **1** on one antenna wire from the connector A on the terminating resistor box to the snap hook **2** on the lanyard **3** connected to the antenna stake B **4** (para 2-5e). Attach the other end loop on the same antenna wire to the snaphook on the lanyard connected to antenna stake C. Attach one of the end loops on the antenna wire from the connector B on the terminating resistor box to the snaphook on the lanyard connected to antenna stake A and the other end loop to the snaphook on the lanyard connected to antenna stake D.

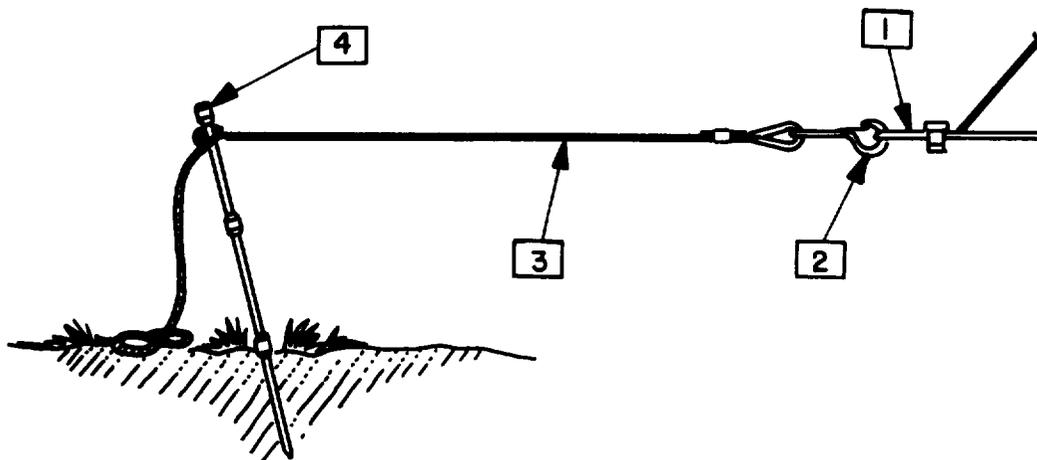

(7) Connect the two loose ends **1** of the antenna wire (going to antenna stakes B and C) to antenna connector A **2** balun **3** connect the two loose ends **4** of the other antenna wire (going to antenna stakes A and D) to antenna connector B **5** on the balun **3**.

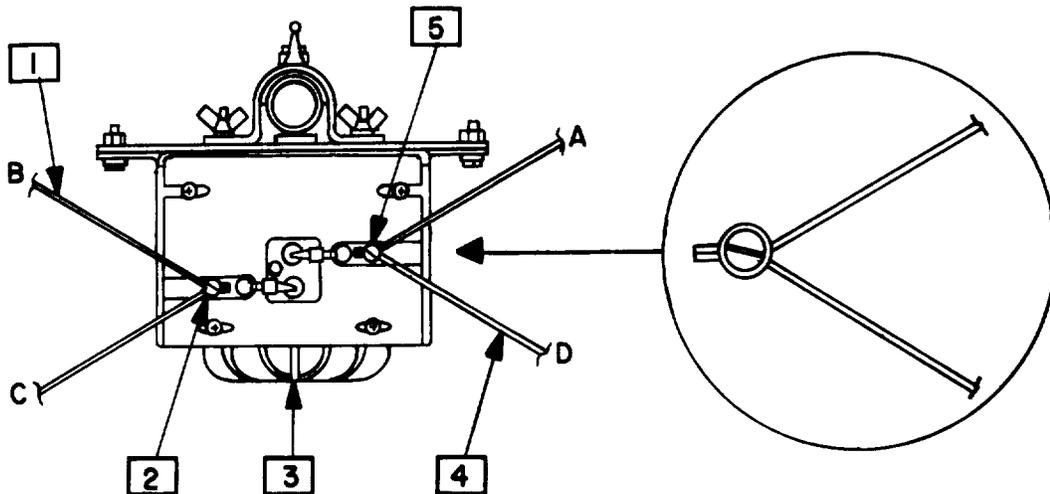

(8) Notify the radio operator to connect the rf cable to the radio.

4-17. Cleaning.

WARNING

The fumes of trichlorotrifluoroethane are toxic. Refer to WARNING page in front of this manual for precautions to follow when using trichlorotrifluoroethane.

- a. Use a dry, clean, lint-free cloth (item 2, appx E) or brush (item 1, appx E) to remove dust or dirt. If necessary, moisten the cloth or brush with trichlorotrifluoroethane (item 3, appx E). After cleaning, wipe dry with a clean cloth.

WARNING

Compressed air is dangerous and can cause bodily harm. Refer to WARNING page in front of this manual for precautions to follow when using compressed air.

- b. Dry, compressed air, not to exceed 29 psi, may be used to remove dirt and dust from inaccessible places.

4-18. Painting and Refinishing.

a. General. Refinishing processes should restore equipment surfaces to original appearance and as-new standards. Minor damage to finishes, such as small scratches, require touchup painting of the affected areas only.

b. Touchup Procedures.

(1) Remove all rust and corrosion by lightly sanding the affected areas with fine sandpaper (item 4, appx E). Clean with solvent and allow to dry.

(2) Apply chemical film as directed in MIL-C-5541 using small cleaning brush. Allow to dry.

(3) Apply zinc chromate primer 0.0004 to 0.0006-inch thick, as directed in Federal Specification TT-P-1757, over the chemical film using small cleaning brush. Allow to dry.

(4) Apply one coat of lusterless enamel paint, as directed in Federal Specification TT-E-526, over the affected area. Allow to dry.

Section VI. PREPARATION FOR STORAGE OR SHIPMENT

4-19. Administrative Storage. Administrative storage of equipment issued to and used by Army activities will have preventive maintenance performed in accordance with the PMCS charts (tables 2-1 and 4-1) before storing. When removing the equipment from administrative storage, PMCS should be performed to assure operational readiness. Administrative storage of equipment is covered in TM 740-90-1.

4-20. Preparation for Storage or Shipment. Prepare the equipment as described for preparation for movement in paragraph 2-6. Preservation, packaging, and packing of military supplies and equipment is covered in TM 38-230-2.

4-21. Storage. Store the equipment in a building, shed, or under cover. If the equipment is to be stored outside, place on a pallet or planking; wrap in a canvas tarp or waterproof cover.

4-22. Packing for Shipment. If available, use the packing materials and shipping cartons in which the equipment was shipped, and reverse the unpacking procedures in paragraphs 4-4 and 4-5.

4-23. Packing Carrying Frame.

a. Insert 11 mast sections in the 11 receptacles in each of two end plates of the carrying frame. Hook the cable and turnbuckle that hold the end plates together and tighten the turnbuckle to secure the 11 mast sections to the end plates. The 11 mast sections and the two end plates form a trough in which the remaining components of the mast assembly are packed.

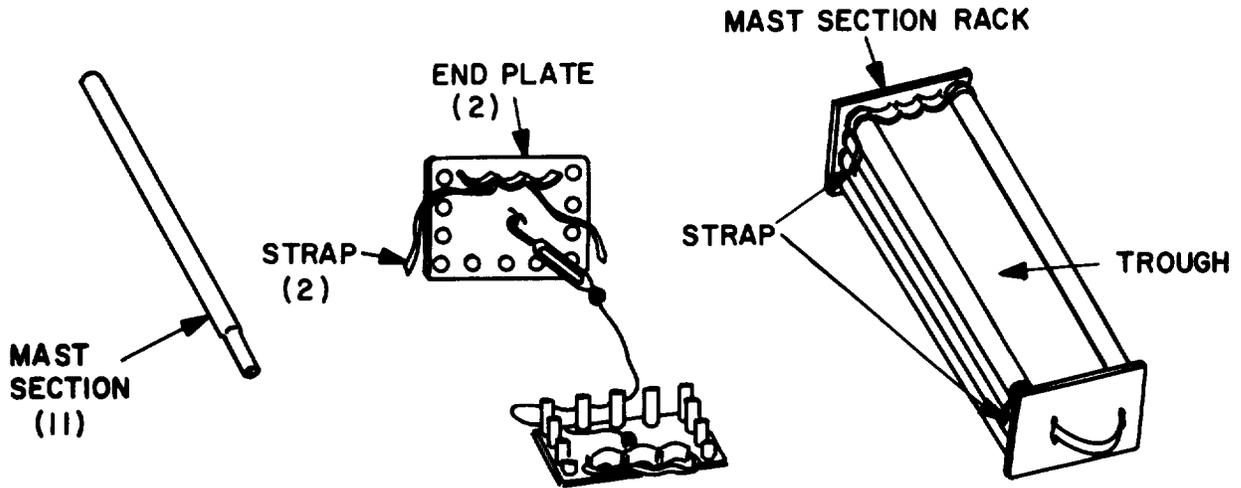

b. Using the guys and halyard to cushion the metal components, place the components listed below in the trough.

NOTE

Three mast sections will be left to be used as instructed in c below.

Quantity	Item
4	Guy MX-381A/GRA-4
4	Guy MX-382A/GRA-4
4	Guy MX-383A/GRA-4
5	Guy Plate MX-1470/U
5	Guy Stake GP-111/G
1	Halyard MX-516/GRA-4
1	Hammer
1	Mast Base AB-154/U
2	Mast Section AB-85/GRA-4
1	Insulator MX-384/GRA-4
1	Plate (6 inch square)

c. Insert the remaining three mast sections in the mast section racks in the two end plates. Using the two straps attached to the mast section racks of the carrying frame, strap the three mast sections in place.

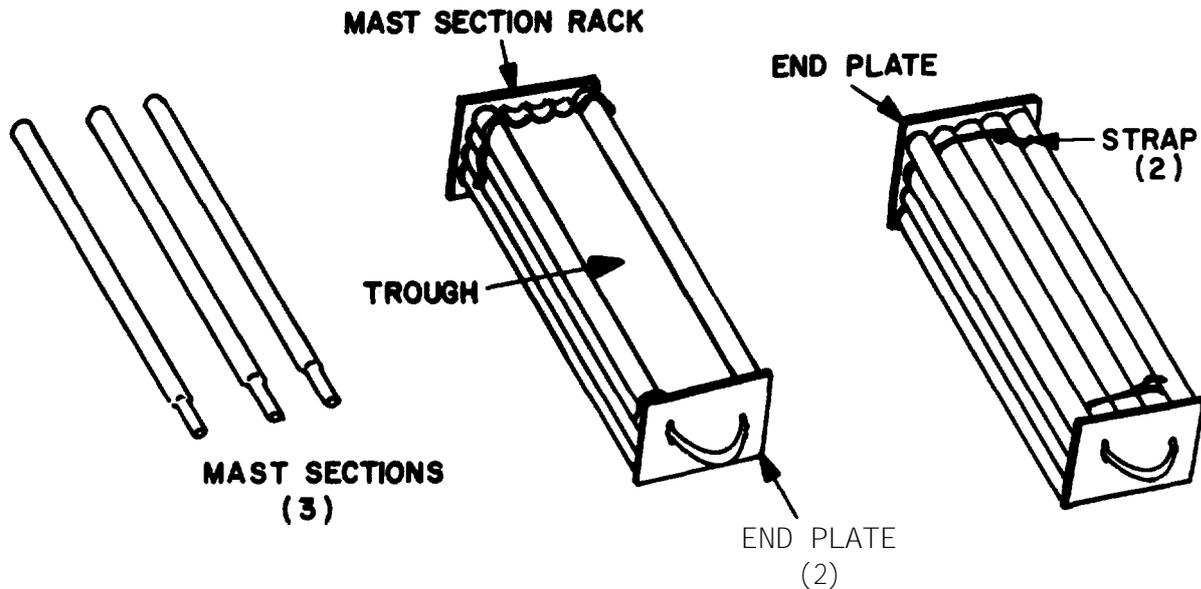

4-24. Packing Carrying Case. Pack the carrying frame (para 4-23) and all remaining components of the AS-3577/GRC into the carrying case.

- a. Open the hinged cover of the carrying case.
- b. Place the packaged carrying frame (para 4-23) to the right and back of the carrying case.
- c. Place the terminating resistor box inside the terminating resistor box stop and place it at the left.
- d. Place the 31 ground rods in the carrying case in front of the carrying frame.
- e. Use the four lanyards as a cushion and place them over the ground rods.
- f. Place the balun to the left, on top of the lanyards.
- g. Place the following also on the lanyards:
 - (1) Goggles.
 - (2) Bag containing 6 conductor splices and electrical tape.
 - (3) Measuring tape, 100-foot.
 - (4) One roll of 2-inch warning strips, and 2 rolls of 3/4-inch warning strips.
 - (5) One roll of antenna wire and the cable adapter.

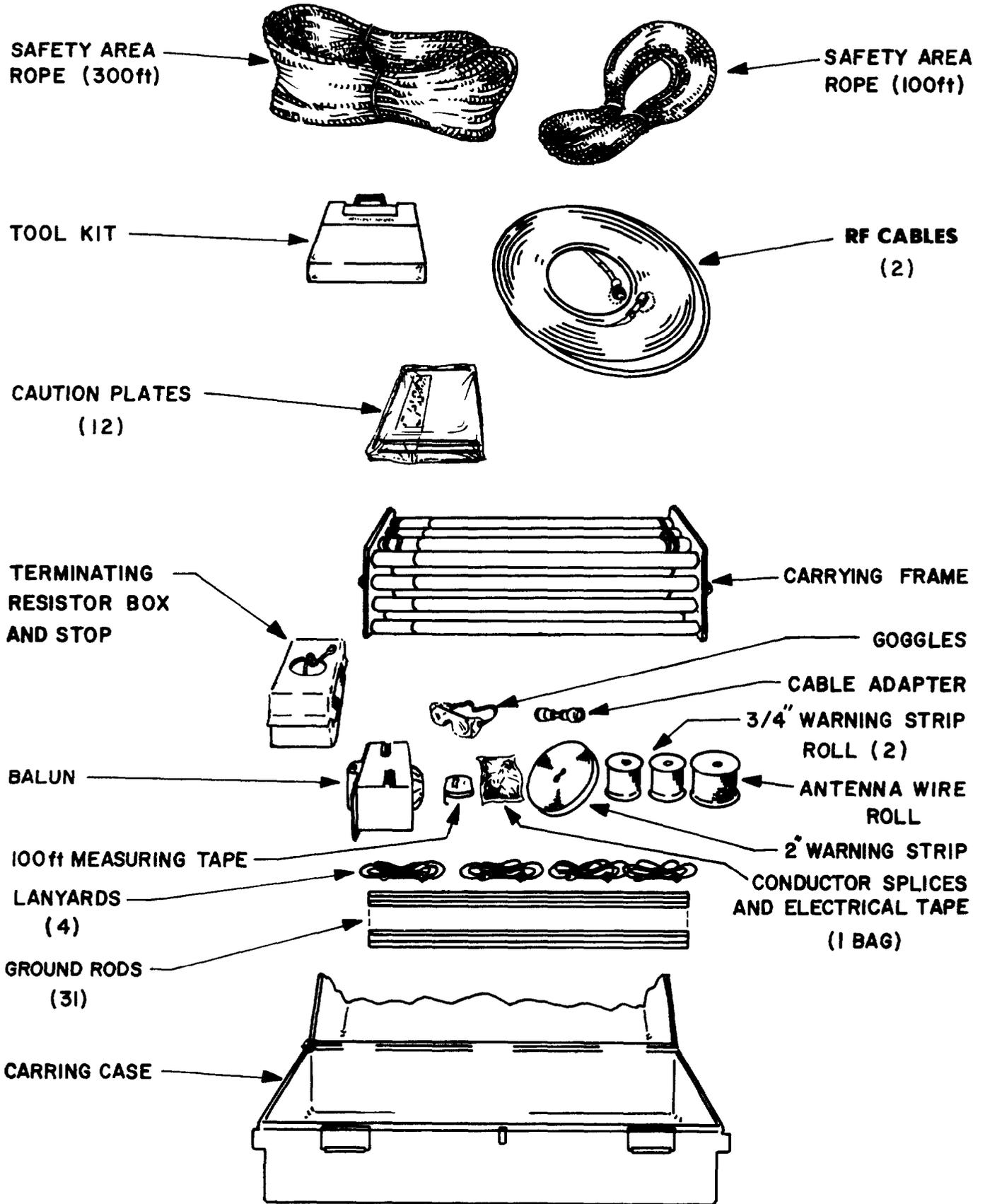

h. Place the caution plates and two rf cables on top of the carrying frame, and the tool kit on top of the caution plates.

i. Place the 300-foot and 100-foot safety area ropes on top of the tool kit and rf cables.

j. Use the snap fasteners to close the hinged cover of the carrying case.

APPENDIX A

REFERENCES

AR 55-38	Reporting of Transportation Discrepancies in Shipments
AR 310-2	Identification and Distribution of DA Publications and Issue of Agency and Command Administrative Publications
AR 735-11-2	Reporting of Item Discrepancies Attributable to Shippers
DA Pam 310-1	Consolidated Index of Army Publications and Blank Forms
DA Pam 310-10	The Standard Army Publication System (STARPUB) Users Guide
DA Pam 738-750	The Army Maintenance Management System (TAMMS)
FM 21-11	First Aid for Soldiers
MIL-STD 129H	Marking for Shipment and Storage
TB 43-0118	Field Instructions for Painting and Preserving Electronics Command Equipment Including Camouflage Pattern Painting of Electrical Equipment Shelters
TB SIG 291	Safety Measures to be Observed When Installing and Using Whip Antennas, Field Type Masts, Towers, Antennas and Metal Poles that are Used with Communications Radar and Direction Finder Equipment
TM 11-2651	Antenna Groups AN/GRA-4 and AN/GRA-12
TM 11-5985-229-12P	Operator and Organizational Maintenance Repair Parts and Special Tools List and Maintenance Allocation Chart, Mast AB-86/GRA-4
TM 11-5985-229-35P	Field and Depot Maintenance Repair Parts and Special Tools List, Mast AB-86/GRA-4
TM 11-5985-371-12-HR	Hand Receipt Covering Contents of Components of End Item (COEI), Basic Issue Items (BII), and Additional Authorization List (AAL) for Antenna AS-3577/GRC (NSN 5985-01-148-1778)
TM 11-6625-3136-12	Operator's and Organizational Maintenance Manual, Spectrum Analyzer AN/USM-489(V) 1 (NSN 6625-01-079-9495)
TM 11-6625-3136-24P	Organizational, Direct Support, and General Support Repair Parts and Special Tools Lists, Spectrum Analyzer AN/USM-489(V)1 (NSN 6625-01-079-9495)

TM 11-5985-371-12&P

TM 11-6625-3136-40

General Support Maintenance Manual, Spectrum Analyzer
AN/USM-489(V)1 (NSN 6625-01-079-9495)

TM 38-230-2

Packaging of Materiel: Preservation (Vol. III)

TM 740-90-1

Administrative Storage of Equipment

TM 750-244-2

Procedures for Destruction of Electronics Materiel to
Prevent Enemy Use (Electronics Command)

APPENDIX B

MAINTENANCE ALLOCATION

Section I. INTRODUCTION

B-1. General. This appendix provides a summary of the maintenance operations for the AS-3577/GRC. It authorizes categories of maintenance for specific maintenance functions on repairable items and components and the tools and equipment required to perform each function. This appendix may be used as an aid in planning maintenance operations.

B-2. Maintenance Function. Maintenance functions will be limited to and defined as follows:

a. Inspect. To determine the serviceability of an item by comparing its physical, mechanical and/or electrical characteristics with established standards through examination.

b. Test. To verify serviceability and to detect incipient failure by measuring the mechanical or electrical characteristics of an item and comparing those characteristics with prescribed standards.

c. Service. Operations required periodically to keep an item in proper operational condition, i.e., to clean (decontaminate), to preserve, to drain, to paint, or to replenish fuel, lubricants, hydraulic fluids, or compressed air supplies.

d. Adjust. To maintain, within prescribed limits, by bringing into proper or exact position, or by setting the operating characteristics to the specified parameters.

e. Align. To adjust specified variable elements of an item to bring about optimum or desired performance.

f. Calibrate. To determine and cause corrections to be made or to be adjusted on instruments or test measuring and diagnostic equipments used in precision measurement. Consists of comparisons of two instruments, one of which is a certified standard of known accuracy, to detect and adjust any discrepancy in the accuracy of the instrument being compared.

g. Install. The act of emplacing, seating, or fixing into position an item, part, module (component or assembly) in a manner to allow the proper functioning of the equipment or system.

h. Replace. The act of substituting a serviceable like-type part, subassembly, or module (component or assembly) for an unserviceable counterpart.

i. Repair. The application of maintenance services (inspect, test, service, adjust, align, calibrate, replace) or other maintenance actions (welding, grinding, riveting, straightening, facing remachining, or resurfacing) to restore

serviceability to an item by correcting specific damage, fault, malfunction, or failure in a part, subassembly, module (component or assembly), end item, or system.

j. Overhaul. The maintenance effort (service/action) necessary to restore an item to a completely serviceable/operational condition as prescribed by maintenance standards (i.e., DMWR) in appropriate technical publications. Overhaul is normally the highest degree of maintenance performed by the Army. Overhaul does not normally return an item to like new condition.

k. Rebuild. Consists of those service/actions necessary for the restoration of unserviceable equipment to a like new condition in accordance with original manufacturing standards. Rebuild is the highest degree of materiel maintenance applied to Army equipment. The rebuild operation includes the act of returning to zero those age measurements (hours, miles, etc.) considered in classifying Army equipments/components.

B-3. Column Entries.

a. Column 1. Group Number. Column 1 lists group numbers, the purpose of which is to identify components, assemblies, subassemblies, and modules with the next higher assembly.

b. Column 2. Component/Assembly. Column 2 contains the noun names of components, assemblies, subassemblies, and modules for which maintenance is authorized.

c. Column 3. Maintenance Functions. Column 3 lists the functions to be performed on the item listed in column 2. When items are listed without maintenance functions, it is solely for the purpose of having the group number in the MAC and RPSTL coincide.

d. Column 4. Maintenance Category. Column 4 specifies, by the listing of "work time" figures in the appropriate subcolumn(s), the lowest level of maintenance authorized to perform the function listed in column 3. This figure represents the active time required to perform that maintenance function at the indicated category of maintenance. If the number or complexity of the tasks within the listed maintenance function vary at different maintenance categories, appropriate "work time" figures will be shown for each category. The number of task-hours specified by the "work time" figure represents the average time required to restore an item (assembly, subassembly, component, module, end item or system) to a serviceable condition under typical field operating conditions. This time includes preparation time, troubleshooting time, and quality assurance/quality control time in addition to the time required to perform the specific tasks identified for the maintenance functions authorized in the maintenance allocation chart. Subcolumns of column 4 are as follows:

- C Operator/Crew
- O Organizational
- F Direct Support
- H General Support
- D Depot

e. Column 5. Tools and Equipment. Column 5 specifies by code, those common tool sets (not individual tools) and special tools, test, and support equipment required to perform the designated function.

f. Column 6. Remarks. Column 6 contains an alphabetic code which leads to the remark in section IV, Remarks, which is pertinent to the item opposite the particular code.

B-4. Tool and Test Equipment Requirements (Sect. III).

a. Tool or Test Equipment Reference Code. The numbers in this column coincide with the numbers used in the tools and equipment column of the MAC. The numbers indicate the applicable tool or test equipment for the maintenance functions.

b. Maintenance Category. The codes in this column indicate the maintenance category allocated the tool or test equipment.

c. Nomenclature. This column lists the noun name and nomenclature of the tools and test equipment required to perform the maintenance functions.

d. National Stock Number. This column lists the National/NATO stock number of the specific tool or test equipment.

e. Tool Number. This column lists the manufacturer's part number of the tool followed by the Federal Supply Code for manufacturers (5-digit) in parentheses.

B-5. Remarks (Sect. IV).

a. Reference Code. This code refers to the appropriate item in section II, column 6.

b. Remarks. This column provides the required explanatory information necessary to clarify items appearing in section II.

Section II. Maintenance Allocation Chart

(1) GROUP NUMBER	(2) COMPONENT/ASSEMBLY	(3) MAINTENANCE FUNCTION	(4) MAINTENANCE CATEGORY					(5) TOOLS AND EQPT.	(6) REMARKS
			c	o	F	H	D		
00	Antenna AS-3577/	Inspect	0.5						A
		Install	2.0					1	
		Test		0.5				2, 3	
		Replace		2.5				2, 3	
		Repair		0.5				3	B
		Overhaul						10	2, 4, 5 6, 7
01	Antenna Mast Assembly AB-86/ GRA-4	Inspect	0.2						A, E
02	Terminating Re- sistor Assembly	Inspect	0.2						A
		Replace		0.5				1	
		Repair		0.2				2, 3	D

SECTION III. TOOL AND TEST EQUIPMENT REQUIREMENTS

TOOL OR TEST EQUIPMENT REF CODE	MAINTENANCE CATEGORY	NOMENCLATURE	NATIONAL/ NATO STOCK NUMBER	TOOL NUMBER
1	C	TOOL KIT TKX-11 (FURNISHED WITH AS-3577/GRC)		
2	O,D	MULTIMETER, DIGITAL AN/PSM-45	6625-01-139-2512	462-(55026)
3	O	TOOL KIT, ELECTRONIC EQUIPMENT TK-101/G	5180-00-064-5178	
4	D	TOOL KIT, ELECTRONIC EQUIPMENT TK-100/G	5180-00-605-0079	
5	D	DIRECTIONAL BRIDGE HP-8721A	6625-00-155-5991	
6	D	TRACKING GENERATOR SG-1122/U:	6625-00-155-5990	
		O DISPLAY SECTION IP-1216(P)/GR	6625-00-424-4370	
		O SPECTRUM ANALYZER RF SECTION PL-1399/U	6625-00-432-5055	
		O SPECTRUM ANALYZER IF SECTION PL-1388/U	6625-00-431-9339	
		OR		
		O SPECTRUM ANALYZER AN/USM-489(V)1 (IN LIEU OF ABOVE THREE ITEMS)	6625-01-079-9495	
7	D	50-OHM TRANSMISSION LINE RG-213 (100 FT)		
		NOTE EQUIVALENT TOOLS OR EQUIPMENT MAY BE SUBSTITUTED FOR THE ABOVE.		

Section IV. Remarks

REFERENCE CODE	REMARKS
A	Visual inspection
B	Repair by replacing antenna wire, balun, cables, and terminating resistor box
C	Complete repair
D	Repair by replacement of pluck-out resistors
E	Refer to TM 11-5985-229-12P, and -35P

APPENDIX E

EXPENDABLE SUPPLIES AND MATERIALS LIST

Section I. INTRODUCTION

E-1. SCOPE.

This appendix lists expendable supplies and materials you will need to operate and maintain the AS-3577/GRC. These items are authorized to you by CTA 50-970, Expendable Items (Except Medical, Class V, Repair parts, and Heraldic Items).

E-2. EXPLANATION-OF COLUMNS.

- a. Column 1 - Item Number. This number is assigned to the entry in the listing and is referenced in the narrative instructions to identify the material (e.g., "use cleaning cloth, item 1, appx E").
- b. Column 2 - Level. This column identifies the lowest level of maintenance that requires the listed item. F - Direct Support Maintenance.
- c. Column 3 - National Stock Number. This is the National stock number assigned to the item; use it to request or requisition the item.
- d. Column 4 - Description. Indicates Federal item name and, if required, a description to identify the item. The last line for each item indicates the Federal Supply Code for Manufacturer (FSCM) in parentheses followed by the part number.
- e. Column 5 - Unit of Measure (U/M). Indicates the measure used in performing the actual maintenance function. This measure is expressed by a two-character alphabetical abbreviation (e.g., ea, in, pr). If the unit of measure differs from the unit of issue, requisition the lowest unit of issue that will satisfy your requirements.

SECTION II. EXPENDABLE SUPPLIES AND MATERIALS LIST

(1) ITEM NO.	(2) LEVEL	(3) NATIONAL STOCK NUMBER	(4) DESCRIPTION PART NO. AND FSCM	(5) UNIT OF MEAS
1	0	5120-00-759-9651	BRUSH, CLEANING (66042)	EA
2	0	8305-00-222-2423	CLOTH, CHEESECLOTH CCC-440 (81348)	YD
3	0	6850-00-984-5853	TRICHLOROTRIFLUOROETHANE, CLEANING COMPOUND FREON PCA MIL-C-81302 (81349)	GL
4	0	5350-00-598-5908	0000 SANDPAPER	ST

APPENDIX F REPAIR PARTS AND SPECIAL TOOLS LIST

SECTION I INTRODUCTION

F-1. Scope

This appendix lists and authorizes spares and repair parts; special tools; special test, measurement, and diagnostic equipment (TMDE), and other special support equipment required for performance of organizational maintenance of the AS-3577/GRC. It authorizes the requisitioning, issue, and disposition of spares, repair parts and special tools as indicated by the source, maintenance and recoverability (SMR) codes.

F-2. General.

This Repair Parts and Special Tools List is divided into the following sections:

a. Section II. Repair Parts List. A list of spares and repair parts authorized by this RPSTL for use in the performance of maintenance. The list also includes parts which must be removed for replacement of the authorized parts. Parts lists are composed of functional groups in ascending numeric sequence, with the parts in each group listed in ascending item number sequence. Figure numbers are listed directly beneath the group header.

b. Section III. Special Tools List. Not applicable.

c. Section IV. National Stock Number and Part Number Index. A list, in National item identification number (NIIN) sequence, of all National stock numbered items appearing in the listings, followed by a list in alphameric sequence of all part numbers appearing in the listings. National stock numbers and part numbers are cross-referenced to each illustration figure and item number appearance.

F-3. Explanation of Columns (Section II and III).

a. Item No. (Column (1)). Indicates the number used to identify items called out in the illustration.

b. SMR Code (Column (2)). The source, maintenance, and recoverability (SMR) code is a five-position code containing supply/requisitioning information, maintenance category authorization criteria, and disposition instruction, as shown in the following breakout:

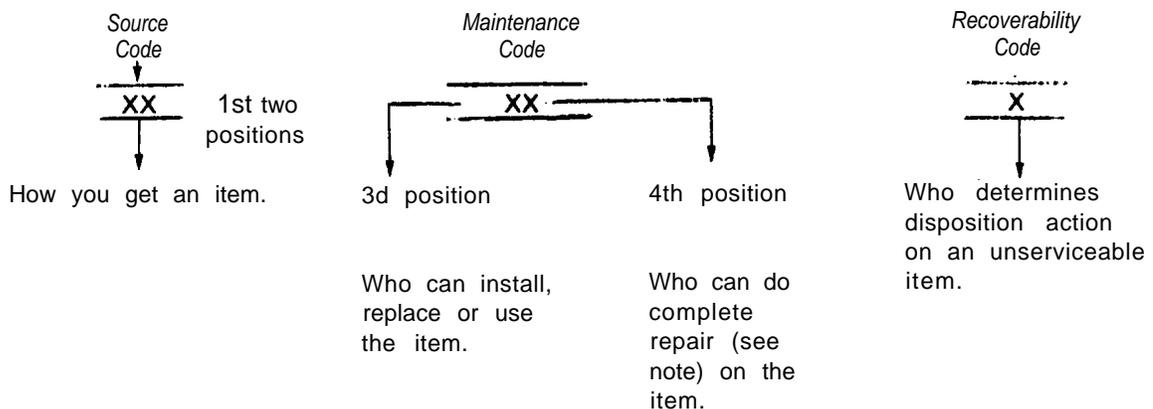

NOTE

complete repair: Maintenance capacity, capability, and authority to perform all corrective maintenance tasks of the "Repair" function in a use/user environment in order to restore serviceability to a foiled item.

(1) *Source Code*. The source code tells you how to get on item needed for maintenance, repair, or overhaul of an end item/equipment. Explanations of source codes follows:

Code

Explanation

PA
PB
PC
PD
PE
PF
PG

Stocked items; use the applicable NSN to request/requisition items with these source codes. They are authorized to the category indicated by the code entered in the third position of the SMR code.

NOTE

Items coded PC are subject to deterioration.

KD
KF
KB

Items with these codes are not to be requested/requisitioned individually. They are part of a kit which is authorized to the maintenance category indicated in the third position of the SMR code. The complete kit must be requisitioned and applied.

MO — Made at erg/
AVUM category
MF — Made at DS/
AVUM category
MH — Made at GS
category
ML — Made at Spec-
ialized Repair
Activity (SRA)
MD — Made at Depot

Items with these codes are not to be requested/requisitioned individually. They must be made from bulk material which is identified by the part number in the description and usable on code (UOC) column and listed in the Bulk Material group of the repair parts list. If the item is authorized to you by the third position code of the SMR code, but the source code indicates it is made at a higher category, order the item from the higher category of maintenance.

AO — Assembled by org/
AVUM category
AF Assembled by DS/
AVIM category
AH Assembled by
GS category
AL Assembled by SRA
AD Assembled by Depot

Items with these codes are not to be requested/requisitioned individually. The parts that make up the assembled item must be requisitioned or fabricated and assembled at the category of maintenance indicated by the source code. If the third position code of the SMR code authorizes you to replace the item, but the source code indicates the item is assembled at a higher category, order the item from the higher category of maintenance.

- XA — Do not requisition an "XA" coded item. Order its next higher assembly.
- XB — If an "XB" item is not available from salvage, order it using the FSCM and part number given.
- XC — Installation drawing, diagram, instruction sheet, field service drawing, that is identified by manufacturers part number.
- XD — Item is not stocked. Order on "XD" coded item through normal supply channels using the FSCM and part number given, if no NSN is available.

NOTE

Cannibalization or controlled exchange, when authorized, may be used as a source of supply for items with the above source codes, except for those source coded "XA" or those aircraft support items restricted by requirements of AR 750-1.

(2) *Maintenance Code.* Maintenance codes tell you the category of maintenance authorized to USE and REPAIR support items. The maintenance codes are entered in the third and fourth positions of the SMR code as follows:

(a) The maintenance code entered in the third position tells you the lowest maintenance category authorized to remove, replace, and use an item. The maintenance code entered in the third position will indicate authorization to one of the following categories of maintenance.

<i>Code</i>	<i>Application/Explanation</i>
c	— Crew or operator maintenance done within organizational or aviation maintenance.
O	— Organizational or aviation unit category can remove, replace, and use the item.
F	— Direct support or aviation intermediate category can remove, replace, and use the item.
H	— General support category can remove, replace, and use the item.
L	— Specialized repair activity can remove, replace, and use the item.
D	— Depot category can remove, replace, and use the item.

(b) The maintenance code entered in the fourth position tells whether or not the item is to be repaired and identifies the lowest maintenance category with the capability to do complete repair (i.e., perform all authorized repair functions). This position will contain one of the following maintenance codes:

NOTE

Some limited repair may be done on the item at a lower category of maintenance, if authorized by the Maintenance Allocation Chart (MAC) and SMR codes.

<i>Code</i>	<i>Application/Explanation</i>
O	— Organizational or aviation unit is the lowest category that can do complete repair of the item.
F	— Direct support or aviation intermediate is the lowest category that can do complete repair of the item.
H	— General support is the lowest category that can do complete repair of the item,
L	— Specialized repair activity (designate the specialized repair activity) is the lowest category that can do complete repair of the item.
D	— Depot is the lowest category that can do complete repair of the item.
z	— Nonreparable. No repair is authorized.
B	— No repair is authorized. (No parts or special tools are authorized for the maintenance of a "B" coded item.) However, the item may be reconditioned by adjusting, lubricating, etc., at the user category.

(3) *Recoverability Code*. Recoverability codes are assigned to items to indicate the disposition action on unserviceable items. The recoverability code is entered in the fifth position of the SMR Code as follows:

<i>Recoverability codes</i>	<i>Application/Explanation</i>
Z	— Nonreparable item. When unserviceable, condemn and dispose of the item at the category of maintenance shown in the third position of SMR Code.
O	— Repairable item. When uneconomically repairable, condemn and dispose of the item at organizational or aviation unit category.
F	— Repairable item. When uneconomically repairable, condemn and dispose of the item at the direct support or aviation intermediate category.
H	— Repairable item. When uneconomically repairable, condemn and dispose of the item at general support category.
D	— Repairable item. When beyond lower level repair capability, return to depot. Condemnation and disposal of item not authorized below depot category.
L	— Repairable item. Condemnation and disposal not authorized below specialized repair activity (SRA).
A	— Item requires special handling or condemnation procedures because of specific reasons (e.g., precious metal content, high dollar value, critical material, or hazardous material). Refer to appropriate manuals/directives for specific instructions.

c. *FSCM (Column (3))*. The Federal Supply Code for Manufacturer (FSCM) is a 5-digit numeric code which is used to identify the manufacturer, distributor, or Government agency, etc., that supplies the item.

d. *Part Number (Column (4))*. Indicates the primary number used by the manufacturer (individual, company, firm, corporation, or Government activity), which controls the design and characteristics of the item by means of its engineering drawings, specifications, standards, and inspection requirements to identify an item or range of items.

NOTE

When you use a NSN to requisition an item, the item you receive may have a different part number from the part ordered.

e. *Description and Usable on Code (UOC)(Column (5))*. This column includes the following information.

(1) The Federal item name and, when required, a minimum description to identify the item.

(2) Items that are included in kits and sets are listed below the name of the kit or set.

(3) The statement "END OF FIGURE" appears just below the last item description in Column (5) for a given figure in both section II and section III.

f. *Qty (Column (6))*. Indicates the quantity of the item used in the breakout shown on the illustration figure, which is prepared for a functional group, subfunctional group, or an assembly. A "V" appearing in this column in lieu of a quantity indicates that the quantity is variable and the quantity may vary from application to application.

F-4. Explanation of Columns (Section IV).

a. National Stock Number (NSN) Index.

(1) *Stock number column.* This column lists the NSN by National item identification number (NIIN) sequence. The NIIN consists of the last nine digits of the NSN. When using this column to locate an item, ignore the first four digits of the NSN. When requisitioning items use the complete NSN (13 digits).

(2) *Fig. column.* This column lists the number of the figure where the item is identified/located. The illustrations are in numerical sequence in sections II and III.

(3) *Item column.* The item number identifies the item associated with the figure listed in the adjacent Fig. column. This item is also identified by the NSN listed on the same line.

b. *Part Number Index.* Part numbers in this index are listed by part number in ascending alphanumeric sequence.

(1) *FSCM column.* This column lists the Federal supply code for manufacturer (FSCM).

(2) *Part number column.* This column indicates the part number assigned to the item.

(3) *Stock number column.* This column lists the National stock number for the associated part number and manufacturer identified in the part number and FSCM columns to the left.

(4) *Fig. column.* This column lists the number of the figure where the item is identified/located in sections II and III.

(5) *Item column.* The item number is that number assigned to the item as it appears in the figure referenced in the adjacent figure number column.

F-5. Special Information.

National stock numbers (NSN's) that are missing from P source coded items have been applied for and will be added to this TM by future change/revision when they are entered in the Army Master Data File (AMDF). Until the NSN's are established and published, submit exception requisitions to: Commander, US Army Communications-Electronics Command and Fort Monmouth, ATTN: AMSEL-MM, Fort Monmouth, NJ 07703 -5000 for the part required to support your equipment.

F-6. How to Locate Repair Parts.

a. *When National stock number or part number is not known.*

(1) *First.* Using the table of contents, determine the assembly group or subassembly group to which the item belongs. This is necessary since figures are prepared for assembly groups and subassembly, and listings are divided into the same groups.

(2) *Second.* Find the figure covering the assembly group or subassembly group to which the item belong,

(3) *Third.* Identify the item on the figure and not the item number.

(4) *Fourth.* Refer to the Repair Parts List for the figure to find the part number for the item number noted on the figure.

(5) *Fifth.* Refer to the Part Number Index to find the NSN, if assigned.

b. *When National stock number or part number is known.*

(1) *First.* Using the Index of National stock numbers and part numbers, find the pertinent National stock number or part number. The NSN index is in National item identification number (NIIN) sequence (para 4a(1)). The part numbers in the part number index are listed in ascending alphameric sequence (para 4b). Both indexes cross-reference you to the illustration figure and item number of the item you are looking for.

(2) *Second.* After finding the figure and item number, verify that the item is the one you're looking for, then locate the item number in the repair parts list for the figure.

F-7. Abbreviations.

Not applicable.

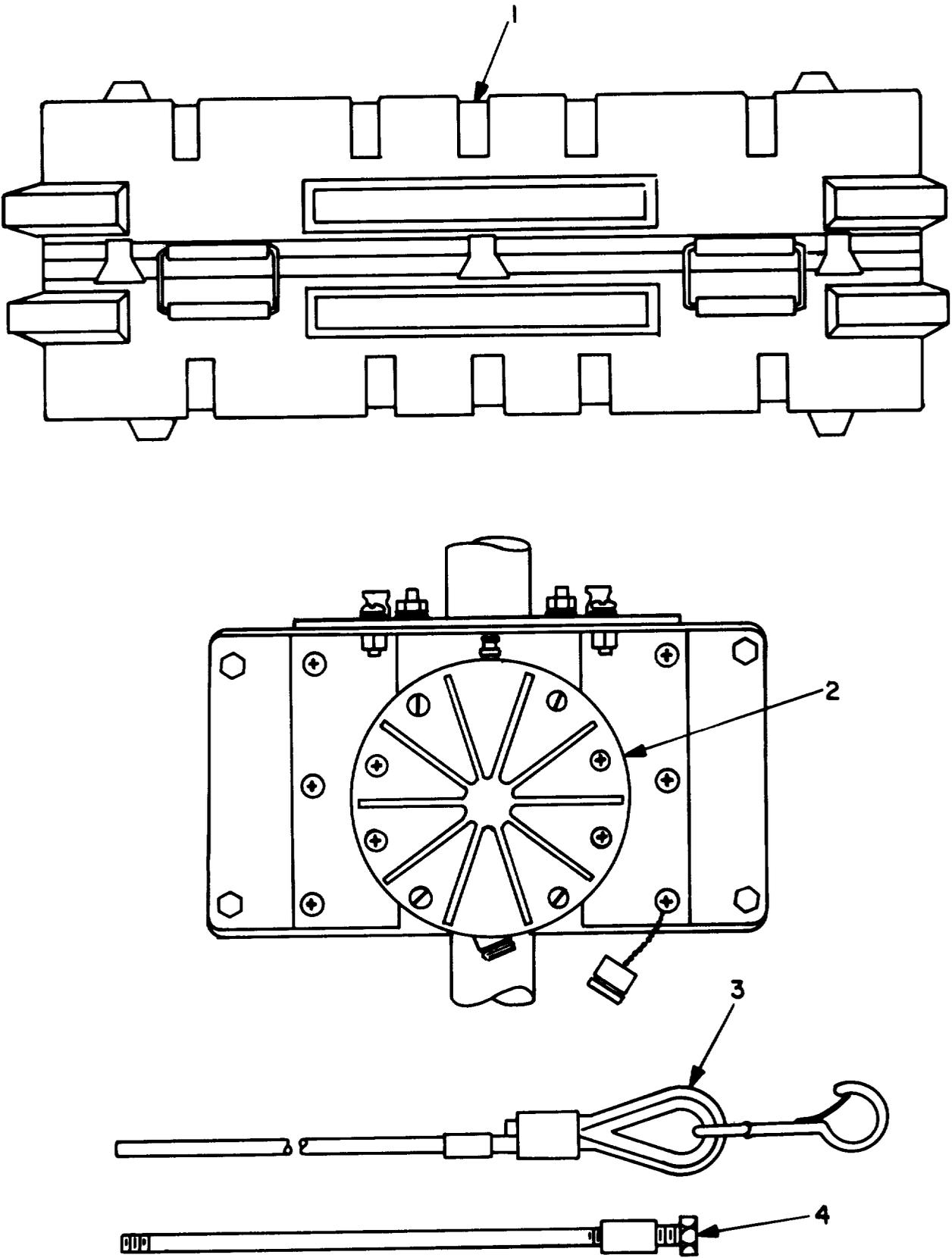

Figure F-1. Antenna AS-3577/GRC
(Sheet 1 of 4)

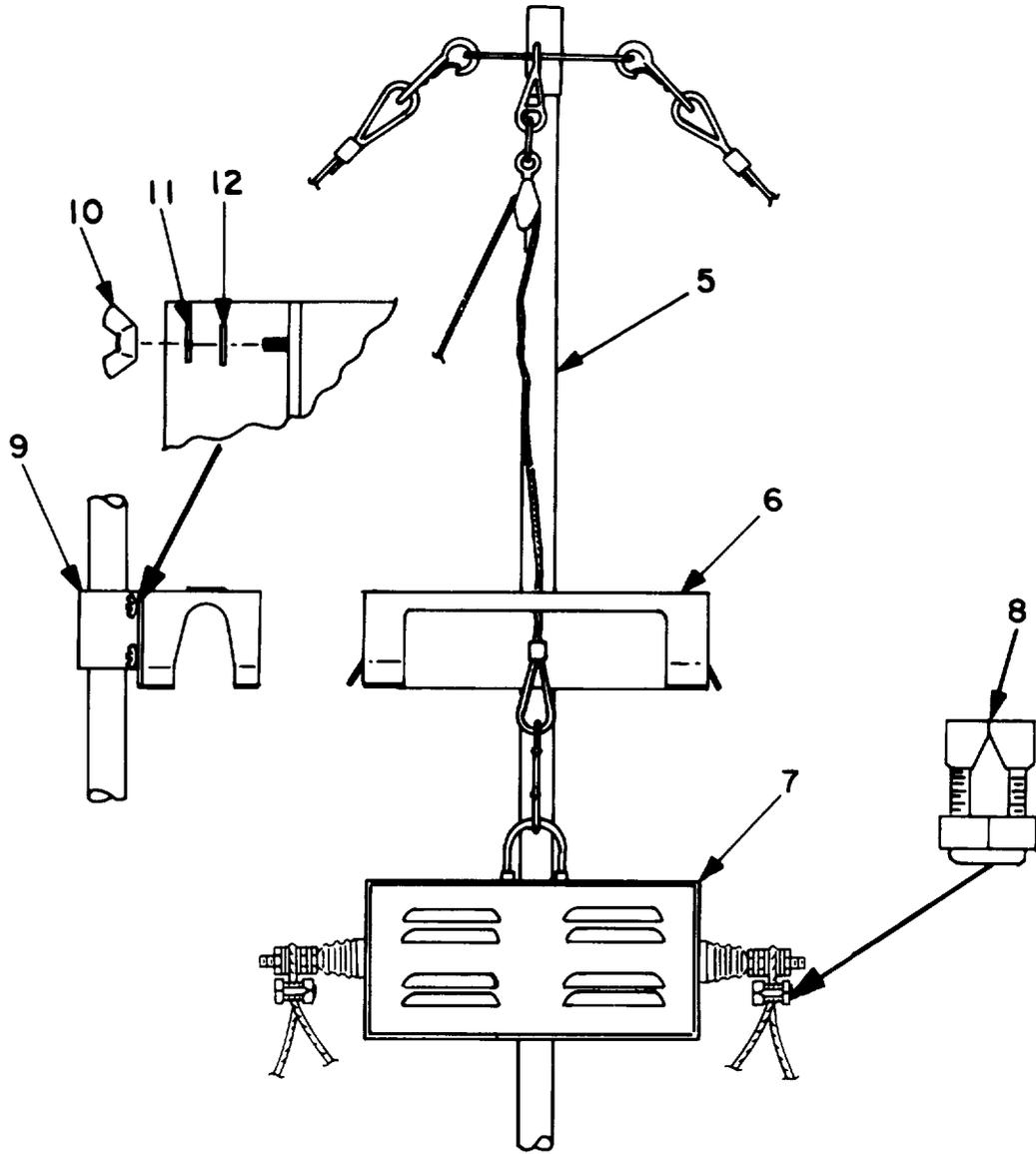

Figure F-1. Antenna AS-3577/GRC
(Sheet 2 of 4)

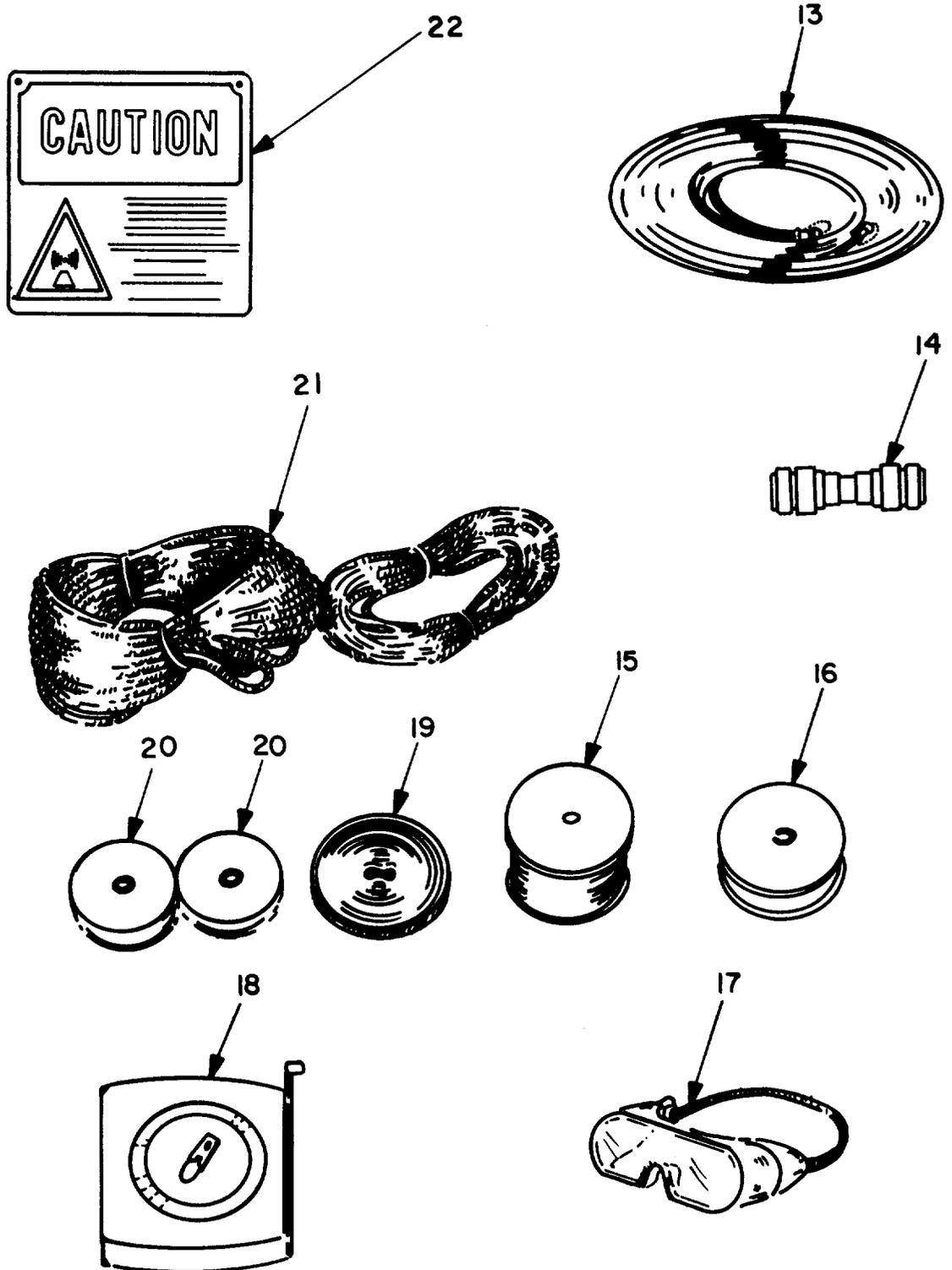

Figure F-1. Antenna AS-3577/GRC
(Sheet 3 of 4)

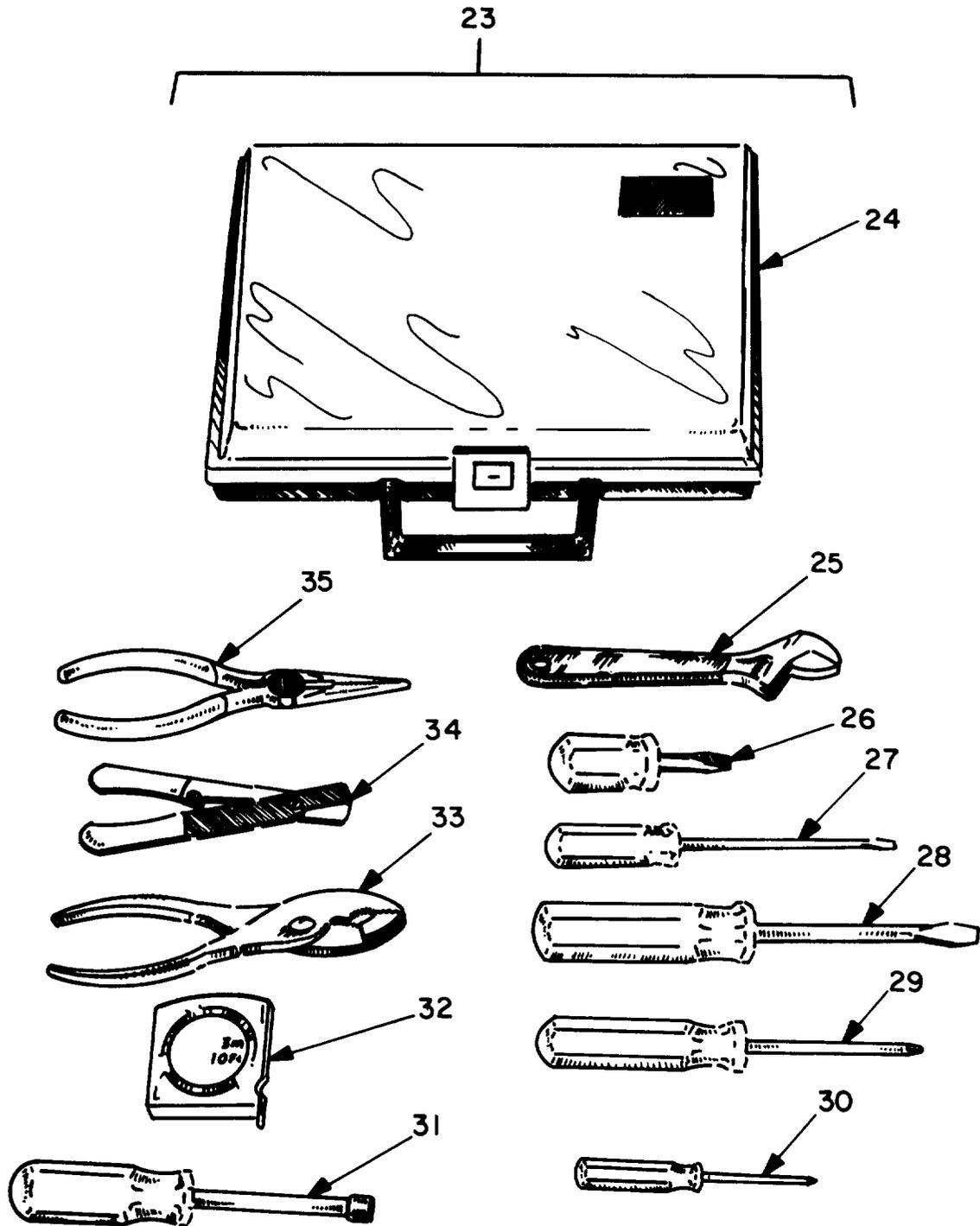

Figure F-1. Antenna AS-3577/GRC
(Sheet 4 of 4)

(1) ITEM NO	(2) SMR CODE	(3) FSCM	(4) PART NUMBER	(5) DESCRIPTION AND USABLE ON CODE (UOC)	(6) QTY
GROUP 00 ANTENA AS -3577/GRC					
FIG.F-1					
1	PAOZZ	80063	A3009801	CASE,CARRYING	1
2	PAOZZ	80063	A3009804	TRANSFORMER ASSY WB	1
3	PAOZZ	80063	A3009785	LANYARD ASSEMBLY	4
4	XBOZZ	81348	TYPE3CLASSB	ROD,GROUND	10
5	PAOOO	80058	AB-86/GRA-4	ANTENNA MAST ASSY	1
REFER TO TM11-2651,TM11-5985-229-12P					
6	XBOZZ	80063	A3009781	STOP,TERMINATING	1
7	PAOOO	80063	A3009780	BOX ASSY,TERM RES	1
8	PAOZZ	80063	A3009808	SPLICE,CONDUCTOR	10
9	XBOZZ	80063	A3009774	CLAMP,TERMINATING	1
10	XDOZZ	96906	MS35425-71	NUT,PLAIN,WING	4
11	PAOZZ	96906	MS35338-139	WASHER,LOCK	4
12	PAOZZ	96906	MS15795-810	WASHER,FLAT	4
13	PAOZF	80063	A3003195	CABLE ASSEMBLY,RADI	2
14	PAOZZ	81349	UG29BU	ADAPTER,CONNECTOR	1
15	PAOZZ	81348	QQW343C14C2T	WIRE,ANTENNA	1
16	PAOZZ	80063	SCC681187-2	TAPE,ELECTRICAL	1
17	PAOZZ	81348	TYPE1GRACL1	GOGGLES,INDUSTRIAL	2
18	PAOZZ	81348	TYPE2CLASSF	TAPE,MEASURE,100 FT	1
19	PAOZZ	80063	A3009814-2	STRIP,WARNING	1
20	PAOZZ	80063	A3009814-1 ACCPP	4CTXA039RNING	1
21	PAOZZ	80063	A3009771-1	ROPE,NYLON	400
22	XBOZZ	80063	A3009772	PLATE,CAUTION	12
23	XBOOO	80063	A3009800	KIT,TOOL	1
24	XBOZZ	96508	MLDCSFORTKX-11	CASE,MOLDED	1
25	PAOZZ	96508	46CG	WRENCH,ADJUSTABLE	1
26	PAOZZ	96508	S141	SCREWDRIVER,STUBBY	1
27	PEOZZ	79061	A130-2	SCREWDRIVER,FLAT TI	1
28	PEOZZ	96508	R144	SCREWDRIVER,FLAT TI	1
29	PEOZZ	96508	X101	SCREWDRIVER,CROSS T	1
30	XDOZZ	96508	P12S	SCREWDRIVER,PHILLIP	1
31	PEOZZ	47805	ND16	WRENCH,SOCKET	1
32	PAOZZ	96508	TM120	TAPE,MEASURE	1
33	PAOZZ	96508	76C	PLIER,SLIP JOINT	1
34	PAOZZ	96508	100X	STRIPPER,WIRE	1
35	PAOZZ	96508	51CG	PLIERS	1

END OF FIGURE

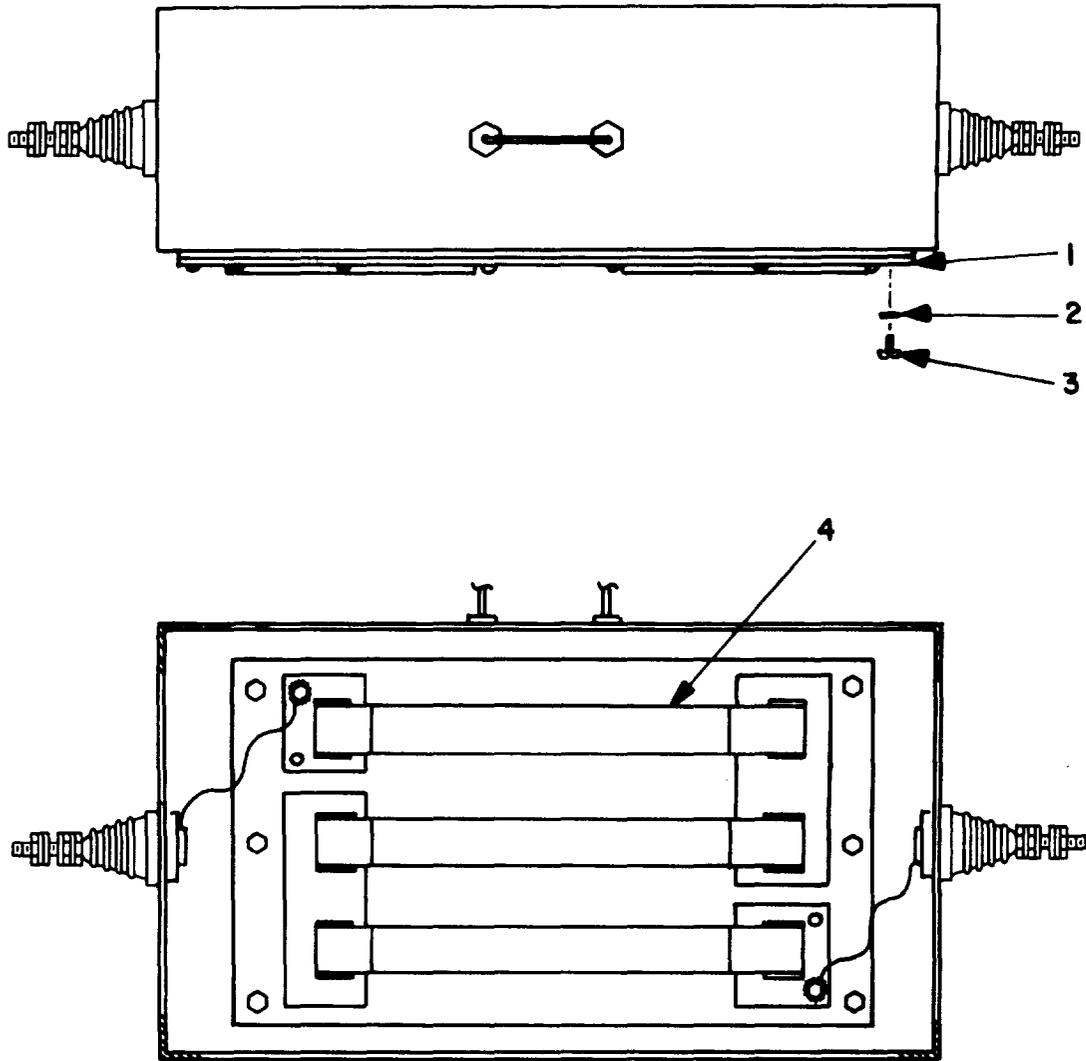

Figure F-2. Terminating Resistor Box Assembly

(1) ITEM NO	(2) SMR CODE	(3) FSCM	(4) PART NUMBER	(5) DESCRIPTION AND USABLE ON CODE (UOC)	(6) QTY
				GROUP TERMINATING RESISTOR BOX ASSEMBLY	
				FIG.F-2	
1	XBOZZ	80063	A3009778	COVER ASSEMBLY	1
2	PAOZZ	96906	MS27183-42	WASHER, FLAT	20
3	PAOZZ	96906	MS51958-65	SCREW, MACHINE	20
4	PAOZZ	80063	A3009796	RESISTOR, POWER	3

END OF FIGURE

—

—

SECTION IV TM11-5985-371-12&P
NATIONAL STOCK NUMBER AND PART NUMBER INDEX

NATIONAL STOCK NUMBER INDEX

STOCK NUMBER	FIG.	ITEM	STOCK NUMBER	FIG.	ITEM
5310-00-014-5850	F-2	2			
5305-00-059-3661	F-2	3			
5120-00-236-2140	F-1	27			
5120-00-240-8716	F-1	29			
5120-00-241-3188	F-1	31			
5310-00-582-5677	F-1	12			
5310-00-933-8121	F-1	11			
5120-01-018-2921	F-1	28			
5995-01-085-1665	F-1	13			
5120-01-197-5408	F-1	35			
5985-01-218-6372	F-1	7			

PART NUMBER INDEX

FSCM	PART NUMBER	STOCK NUMBER	FIG.	ITEM
80058	AB-86/GRA-4		F-1	5
79061	A130-2	5120-00-236-2140	F-1	27
80063	A3003195	5995-01-085-1665	F-1	13
80063	A3009771-1		F-1	21
80063	A3009772		F-1	22
80063	A3009774		F-1	9
80063	A3009778		F-2	1
80063	A3009780	5985-01-218-6372	F-1	7
80063	A3009781		F-1	6
80063	A3009785		F-1	3
80063	A3009796		F-2	4
80063	A3009800		F-1	23
80063	A3009801		F-1	1
80063	A3009804		F-1	2
80063	A3009808		F-1	8
80063	A3009814-1 ACCPP		F-1	20
80063	A3009814-2		F-1	19
96508	MLDCSFORTKX-11		F-1	24
96906	MS15795-810	5310-00-582-5677	F-1	12
96906	MS27183-42	5310-00-014-5850	F-2	2
96906	MS35338-139	5310-00-933-8121	F-1	11
96906	MS35425-71		F-1	10
96906	MS51958-65	5305-00-059-3661	F-2	3
47805	ND16	5120-00-241-3188	F-1	31
96508	P12S		F-1	30
81348	QQW343C14C2T		F-1	15
96508	R144	5120-01-018-2921	F-1	28
80063	SCC681187-2		F-1	16
96508	S141		F-1	26
96508	TM120		F-1	32
81348	TYPE1GRACL1		F-1	17
81348	TYPE2CLASSF		F-1	18
81348	TYPE3CLASSB		F-1	4
81349	UG29BU		F-1	14
96508	X101	5120-00-240-8716	F-1	29
96508	100X		F-1	34
96508	46CG		F-1	25
96508	51CG	5120-01-197-5408	F-1	35
96508	76C		F-1	33

GLOSSARY

Section I. Abbreviations

Following is an alphabetical listing of the abbreviations used in this manual. The exact word or phrase for which each abbreviation is used is identified.

AAL	Additional Authorization List
AWG	American Wire Gage
BII	Basic Issue Items
COEI	Components of End Item
DISREP	Discrepancy in Shipment Report
EA	Each
EIR	Equipment Improvement Recommendations
ESML	Expendable Supplies and Materials List
FSCM	Federal Supply Code for Manufacturer
GL	Gallon
hf	High Frequency
HR	Hand Receipt
Kg	Kilogram
Km	Kilometer
MAC	Maintenance Allocation Chart
MHz	MegaHertz
MHO	Modification Work Order
NATO	North Atlantic Treaty Organization
NIIN	National Item Identification Number
NSN	National Stock Number
PMCS	Preventive Maintenance Checks and Services
rf	Radio Frequency
ROD	Report of Discrepancy
RPSTL	Repair Parts and Special Tools List
ST	Sheet
SMR	Source, Maintenance and Recoverability
SSB	Single Side Band
TMDE	Test Measurement and Diagnostic Equipment
U/M	Unit of Measure
VSWR	Voltage Standing Wave Ratio
YD	Yard

Section II. Terms

Following is an alphabetical listing of unusual terms used in this manual and the definition of each.

- Balun - An impedance-matching device (transformer) for antennas used between radio transmission line (rf cable) and the antenna wire (delta).
- Cleat - A fitting with two projecting horns around which a rope may be fastened.
- Delta - Shaped or formed like the Greek letter A.
- Halyard - A rope or tackle for raising or lowering an object.
- Lanyard - A nylon rope for fastening the antenna rod to the baseline of the delta antenna.
- Plateau - A large level area situated above the adjacent land.

TM 11-5985-371-12&P

Taut - Tightly drawn, not slack or sagging.

Trough - A long shallow, open boxlike container or space.

INDEX

	<u>PAGE</u>
A	
Abbreviations	Glossary 1
Administrative Storage	1-2
Antenna	
Assembly	2-3
Schematic Diagram	4-11
Siting	2-3
Stake Placement	2-5
Wire, Preparation	2-16
Assembly	
Antenna	2-3
Mast	2-8
Attaching	
Balun to Mast	2-15
Ground Rod and Grounding Cable	2-19
Guys to Mast	2-9
Halyard to Mast	2-9
Terminating Resistor Stop to Mast	2-8
Terminating Resistor Box to Halyard	2-8
Antenna Wires to Lanyards	2-17
Conductor Splices to Antenna Wires	2-16
B	
Balun	
Attaching to Mast	2-15
Removal From Mast	2-27
Replacement	4-19
C	
Capabilities, Equipment	1-3
Checks and Services, Preventive Maintenance	
Operator	2-2
Organizational	4-7
Cleaning	4-23
Components, Major	
Description	1-5
Removal	4-16
Repair/Replace	4-16
Configuration Differences	1-7
Consolidated Index of Army Publications and Blank Forms	1-1
D	
Data, Equipment	1-3
Description of Major Components	1-5



Destruction of Electronics Materiel to Prevent Enemy Use	1-2
Disassembly	
Antenna	2-23
Mast	2-29
Safety Area Boundary	2-25
Disconnecting Ground Rod and Grounding Cable	2-24
Disconnecting Rf Cable	2-24
Double Delta Antenna Assembly	2-15

E

Equipment	
Data	1-3
Description and Data	1-5
Purpose	1-1
Reporting Improvements and Recommendations	1-1
Unpacking the	4-1
Expendable Supplies and Materials	E-1

F

Features, Equipment	1-3
Forms and Records, Maintenance	1-1

G

Ground Rod and Grounding Cable	
Placement	2-19
Removal	2-24
Guy	
Attaching to Mast and Guy Stakes	2-9
Removal	2-28
Guy Stake	
placement	2-5
Removal	2-28

H

Hal yard	
Attaching to Mast	2-9
Removal	2-28
Hand Receipt (-HR) Manual	1-1

I

Improvements, Reporting	1-1
Indicators, Operator's Controls and	2-1
Installation	
Unusual Conditions	2-29
Usual Conditions	2-3

L

Location of Major Components	1-5
--	-----

Lowering the Mast	2-27
Lubrication	3-1

M

Maintenance Forms, Records and Reports	1-1
Manuals, Reference	A-1
Maintenance Allocation Chart	B-4
Maintenance	
Operator/Crew	3-1
Forms and Records	1-1
Organizational	4-16
Records, Forms and	1-1
Major Components, Location and Description of	1-5
Mast Base Placement	2-4

N

Nomenclature Cross-Reference List	1-2
---	-----

O

Operation	2-1
Operator Preventive Maintenance Checks and Services (PMCS)	2-2
Operator's Controls and Indicators	2-1
Organizational	
Maintenance Procedures	4-16
Troubleshooting	4-11
Organizational Preventive Maintenance Checks and Services	4-7

P

Packing	
Carrying Case	4-26
Carrying Frame	4-25
Painting and Refinishing	4-24
Preparation for	
Storage or Shipment	4-24
Use	2-3
Preventive Maintenance Checks and Services, Operator	2-2
Preventive Maintenance Checks and Services, Organizational	4-7
Principles of Operation	4-11
Purpose of Equipment	1-1

R

Raising Mast	2-14
Receipt, Service of Materiel Upon	4-1
Recommendations, Reporting Equipment Improvement and	1-1
Records, Maintenance of Forms and	1-1
References	A-1
Removal and Replacement of	
Antenna Wire	4-20

Balun	4-19
Terminating Resistor Box	4-16
Repacking Carrying Case	4-26
Repacking Carrying Frame	4-25
Repair Parts and Special Tools List	F-1
Reporting Equipment Improvement and Recommendations	1-1

S

Safety Area Boundary	
Erection	2-20
Disassembly	2-25
Scope of Manual	1-1
Service Upon Receipt	4-1
Shipment, Preparation for	4-24
Siting	2-3
Storage, Preparation for	1-2

T

Terminating Resistor Box	
Installation	2-17
Removal /Replacement	4-16
Repair	4-16
Terminating Resistor Box Stop	
Installation	2-8
Removal	2-29
Terms, Definition of	Glossary-1
Testing	
Balun	4-12
Terminating Resistor Box	4-15
Troubleshooting	
Operator	3-1
Organizational	4-11

U

Unpacking	
Carrying Case	4-1
Carrying Frame	4-4

W

Wire, Antenna Delta	
Preparation	2-16
Removal	4-20
Replacement	4-21

RECOMMENDED CHANGES TO EQUIPMENT TECHNICAL PUBLICATIONS



THEN... JOT DOWN THE DOPE ABOUT IT ON THIS FORM. CAREFULLY TEAR IT OUT. FOLD IT AND DROP IT IN THE MAIL!

SOMETHING WRONG WITH THIS PUBLICATION?

FROM (PRINT YOUR UNIT'S COMPLETE ADDRESS)

Commander
Stateside Army pot
ATTN: AMSTA-US
Stateside, N.J. 07703-5007

DATE SENT

4 April 1978

PUBLICATION NUMBER

TM 11-5840-340-14&P

PUBLICATION DATE

23 Jan 74

PUBLICATION TITLE

Radar Set AN/PRC-76

BE EXACT. PIN-POINT WHERE IT IS

PAGE NO	PARA-GRAPH	FIGURE NO	TABLE NO
2-25	2-28		
3-10	3-3		3-1
5-6	5-8		
E-5			
E-8		E-3	
E-9			

IN THIS SPACE TELL WHAT IS WRONG AND WHAT SHOULD BE DONE ABOUT IT:

Recommend that the installation antenna alignment procedure be changed throughout to specify a 2° IFF antenna lag rather than 1°.

REASON: Experience has shown that with only a 1° lag, the antenna servo system is too sensitive to wind gusting in excess of 25 knots, and has a tendency to rapidly accelerate and decelerate as it hunts, causing strain to the drive train. Hunting is minimized by adjusting the lag to 2° without degradation of operation.

Item 5, Function column Change "2 db" to "3db."

REASON: The adjustment procedure for the TRANS POWER FAULT indicator calls for a 3 db (500 watts) adjustment to light the TRANS POWER FAULT indicator.

Add new step f.1 to read, "Replace cover plate removed in step e.1, above."

REASON: To replace the cover plate.

For item 2, change the NSN to read: 5835-00-134-9186.

REASON: Accuracy.

Identify the cover on the junction box (item no. 5).

REASON: It is a separate item and is not called out on figure 19.

Add the cover of the junction box as an item in the listing for figure 19.

REASON: Same as above.

PRINTED NAME, GRADE OR TITLE, AND TELEPHONE NUMBER

SSG I. M. DeSpirito 999-1776

SIGN HERE

TEAR ALONG PERFORATED LINE

FILL IN YOUR
UNIT'S ADDRESS

FOLD BACK

DEPARTMENT OF THE ARMY

POSTAGE AND FEES PAID
DEPARTMENT OF THE ARMY
DOD 314



OFFICIAL BUSINESS
PENALTY FOR PRIVATE USE \$300

SAMPLE

Commander
US Army Communications-Electronics Command
and Fort Monmouth
ATTN: AMSEL-ME-MP
Fort Monmouth, New Jersey 07703-5007

TEAR ALONG PERFORATED LINE



THEN...JOT DOWN THE DOPE ABOUT IT ON THIS FORM. CAREFULLY TEAR IT OUT, FOLD IT AND DROP IT IN THE MAIL.

SOMETHING WRONG WITH THIS PUBLICATION?

FROM: (PRINT YOUR UNIT'S COMPLETE ADDRESS)

DATE SENT

PUBLICATION NUMBER

TM 11-5985-371-12&P

PUBLICATION DATE

1 Sept 1986

PUBLICATION TITLE

Antenna AS-3577/GRC

BE EXACT PIN-POINT WHERE IT IS

PAGE NO.	PARA-GRAPH	FIGURE NO.	TABLE NO.

IN THIS SPACE TELL WHAT IS WRONG AND WHAT SHOULD BE DONE ABOUT IT:

PRINTED NAME GRADE OR TITLE AND TELEPHONE NUMBER

SIGN HERE

TEAR ALONG PERFORATED LINE

FILL IN YOUR
UNIT'S ADDRESS

FOLD BACK

DEPARTMENT OF THE ARMY

OFFICIAL BUSINESS
PENALTY FOR PRIVATE USE \$300

POSTAGE AND FEES PAID
DEPARTMENT OF THE ARMY
DOD 314



TEAR ALONG PERFORATED LINE

Commander
US Army Communications-Electronics Command
and Fort Monmouth
ATTN: AMSEL-ME-MP
Fort Monmouth, New Jersey 07703-5007

FILL IN YOUR
UNIT'S ADDRESS

FOLD BACK

DEPARTMENT OF THE ARMY

OFFICIAL BUSINESS
PENALTY FOR PRIVATE USE \$300

POSTAGE AND FEES PAID
DEPARTMENT OF THE ARMY
DOD 314



TEAR ALONG PERFORATED LINE

Commander
US Army Communications-Electronics Command
and Fort Monmouth
ATTN: AMSEL-ME-MP
Fort Monmouth, New Jersey 07703-5007

RECOMMENDED CHANGES TO EQUIPMENT TECHNICAL PUBLICATIONS



SOMETHING WRONG WITH THIS PUBLICATION?

THEN...JOT DOWN THE DOPE ABOUT IT ON THIS FORM. CAREFULLY TEAR IT OUT, FOLD IT AND DROP IT IN THE MAIL.

FROM: (PRINT YOUR UNIT'S COMPLETE ADDRESS)

DATE SENT

PUBLICATION NUMBER
TM 11-5985-371-12&P

PUBLICATION DATE
1 Sept 1986

PUBLICATION TITLE
Antenna AS-3577/GRC

BE EXACT PIN-POINT WHERE IT IS

PAGE NO.	PARA-GRAPH	FIGURE NO.	TABLE NO.
----------	------------	------------	-----------

IN THIS SPACE TELL WHAT IS WRONG AND WHAT SHOULD BE DONE ABOUT IT:

TEAR ALONG PERFORATED LINE

PRINTED NAME GRADE OR TITLE AND TELEPHONE NUMBER

SIGN HERE

DA FORM 2028-2
1 JUL 79

PREVIOUS EDITIONS
ARE OBSOLETE

P.S. IF YOUR OUTFIT WANTS TO KNOW ABOUT YOUR RECOMMENDATION MAKE A CARBON COPE OF THIS AND GIVE IT TO YOUR HEADQUARTERS.

FILL IN YOUR
UNIT'S ADDRESS

FOLD BACK

DEPARTMENT OF THE ARMY

OFFICIAL BUSINESS
PENALTY FOR PRIVATE USE \$300

POSTAGE AND FEES PAID
DEPARTMENT OF THE ARMY
DOD 314



TEAR ALONG PERFORATED LINE

Commander
US Army Communications-Electronics Command
and Fort Monmouth
ATTN: AMSEL-ME-MP
Fort Monmouth, New Jersey 07703-5007

By Order of the Secretary of the Army:

JOHN A. WICKHAM JR.
General, United States Army
Chief of Staff

Official:

R. L. DILWORTH
Brigadier General, United States Army
The Adjutant General

Distribution:

To be distributed in accordance with special list.

★ U.S. GOVERNMENT PRINTING OFFICE: 1986 - 605-042/40092

This publication is required for official use or for administrative or operational purposes only. Distribution is limited to US Government Agencies. Other requests for this document must be referred to Commander, US Army Communications-Electronics Command and Fort Monmouth, ATTN: AMSEL-ME-P, Fort Monmouth, NJ 07703 5007.

PIN: 060236